



# ***Durco<sup>®</sup> T4E – PFA Lined Plug Valves*** ***ANSI 150 • DIN PN16 • ANSI 300***

The New Generation of High-Performance Lined Chemical Service Valves



***Experience In Motion***

# T4E – PFA Lined Chemical Service Valve

The T4E series is designed and developed with the latest technology and therefore very suitable for the chemical process industries. The T4E valves provide maximum corrosion resistance and the elimination of product contamination at reasonable costs.

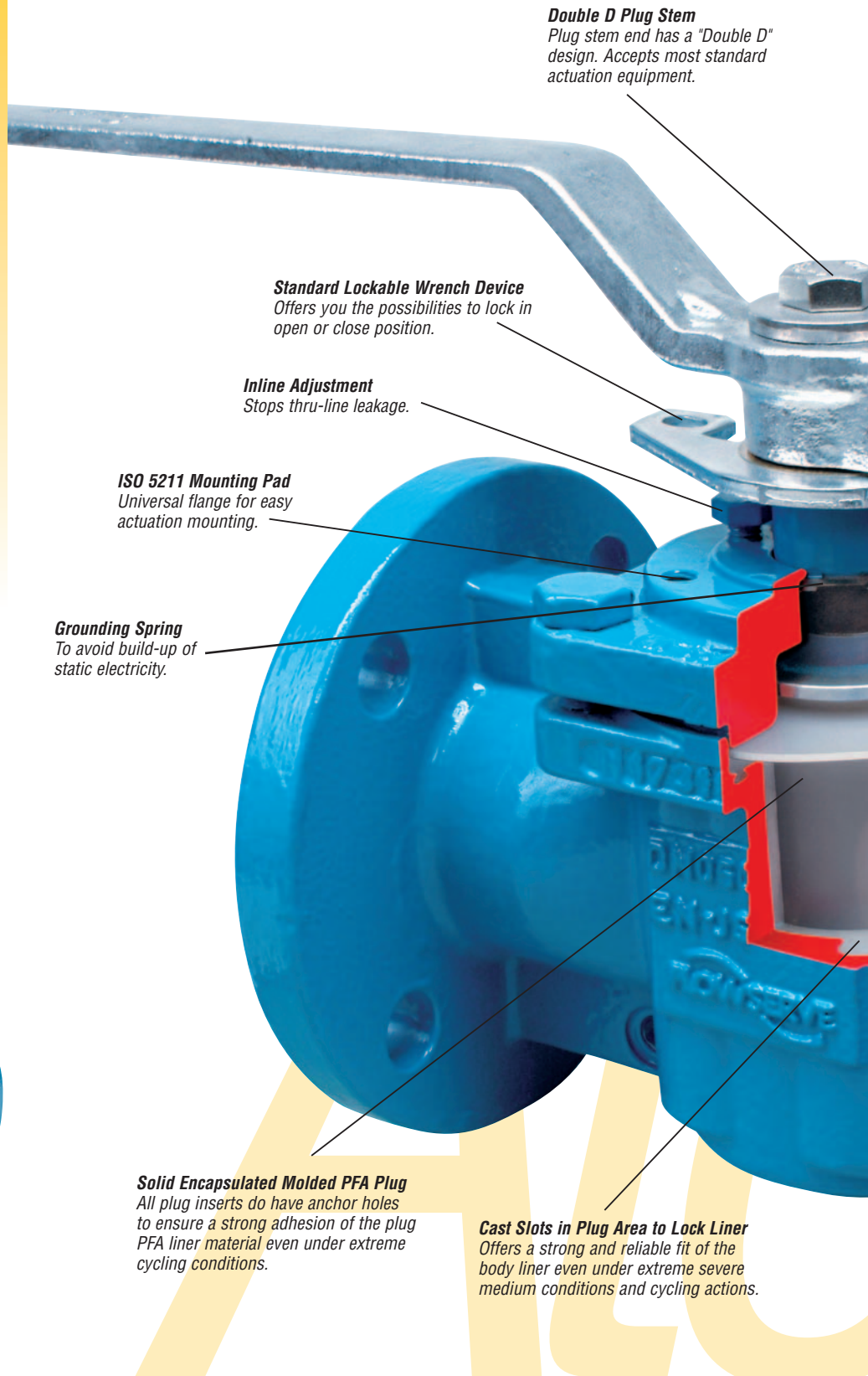

**Double D Plug Stem**  
Plug stem end has a "Double D" design. Accepts most standard actuation equipment.

**Standard Lockable Wrench Device**  
Offers you the possibilities to lock in open or close position.

**Inline Adjustment**  
Stops thru-line leakage.

**ISO 5211 Mounting Pad**  
Universal flange for easy actuation mounting.

**Grounding Spring**  
To avoid build-up of static electricity.

**Solid Encapsulated Molded PFA Plug**  
All plug inserts do have anchor holes to ensure a strong adhesion of the plug PFA liner material even under extreme cycling conditions.

**Cast Slots in Plug Area to Lock Liner**  
Offers a strong and reliable fit of the body liner even under extreme severe medium conditions and cycling actions.

## Available in Broad Size Range and Extended Pressure Class

- T4E1 ANSI Class 150 is available in sizes 1/2" through 12"
- T4E2 DIN Class PN16 is available in sizes DN15 through DN150
- T4E3 ANSI Class 300 is available in sizes 1/2" through 8"

Available with pneumatic or electric actuators for on-off or modulating "control" applications. Contact Flowserve Ahaus for availability V-port control plugs.

All T4E series are rated to 30 inches Hg vacuum, at ambient temperature.

### T4E Series Offers an Extended Pressure Class:

- T4E1 ANSI Class 150 is rated 17.2 bar at 204°C (17.24 bar at 80°C)
- T4E2 DIN Class PN16 is rated 16 bar at 204°C (17.24 bar at 80°C)
- T4E3 ANSI Class 300 is rated 22 bar at 204°C (51.03 bar at 80°C)

**Benefits that give you that extra security which you will appreciate when using the Flowserve T4E1, T4E2 and T4E3.**

A perfectly fixed PFA body liner is well anchored to the body by means of machined and cast T-slots. The solid encapsulated/anchored PFA plug liner material ensures a strong adhesion. Due to this selected way of anchorage from both body and plug liner make these T4E series so suitable for extreme service and vacuum conditions. The PFA body liner covers all wetted surfaces in the body and the plug extends are sufficiently covered as well.

Due to its large sealing surface a drop-tight shut-off is assured.

In addition to the large sealing area sealing is both upstream and downstream and is totally independent of line pressure.

A secondary dynamic self-adjusting, self-energized PFA reverse lip diaphragm prevents stem leakage. (Optional: stainless steel diaphragm support)

Should line pressure force liquid to the stem seal area, the self-energizing PFA reverse lip diaphragm will be pushed against the stem surface and avoid external leakage.

You never replace valve seats; you only reseal the plug with a quick and easy in-line adjustment.

An open-end wrench and a few seconds are the extent of your maintenance requirements.

There are:

- No seats to replace
- No lengthy production disruption
- No piping disconnection
- No complicated, time-consuming maintenance procedures
- No hazards to personnel

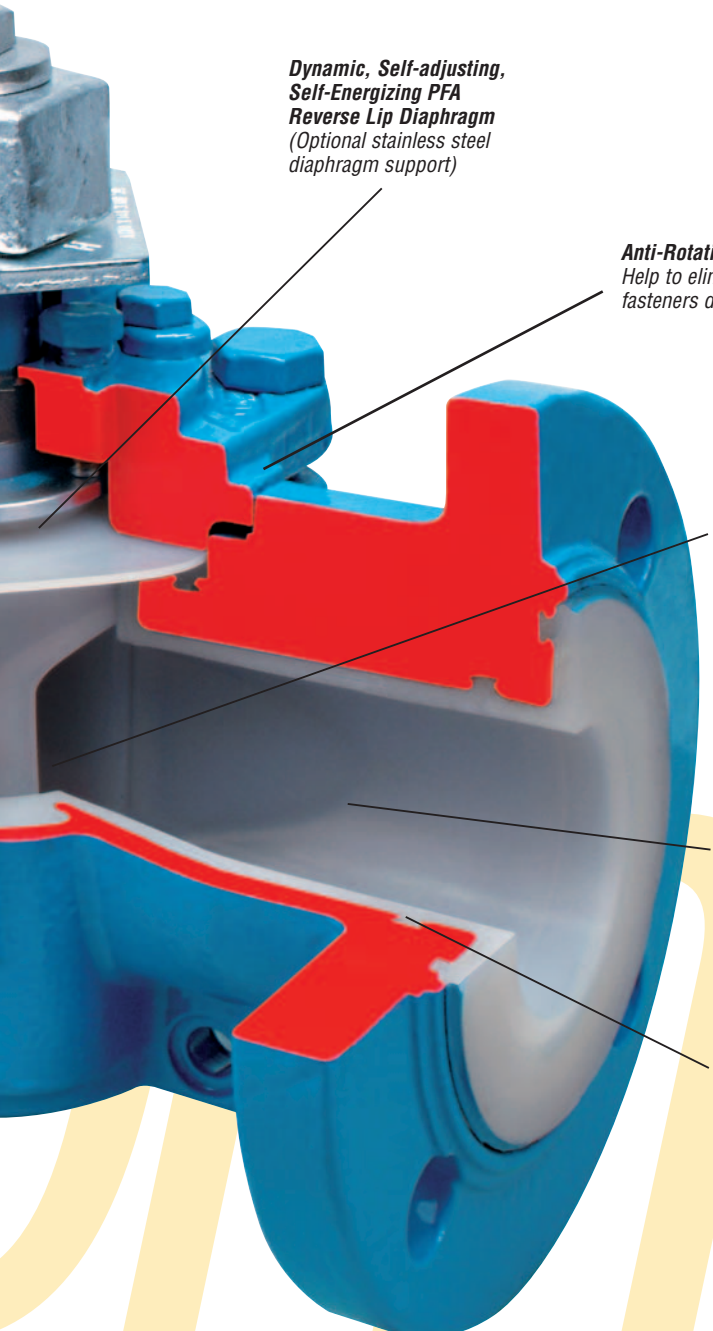

**Dynamic, Self-adjusting, Self-Energizing PFA Reverse Lip Diaphragm**  
(Optional stainless steel diaphragm support)

**Anti-Rotating Lugs**  
Help to eliminate stress on fasteners during actuation.

**Well Dimensioned Ports**  
Offer good  $K_v/C_v$  values.

**High Quality PFA Liner**  
Protects the body and forms the flange gasket. The PFA liner is resistance against a wide variation of chemical products.

**T-Slots in Critical Areas to Lock Liner Against Body Wall**  
Advantage will be a tight and perfect fit of the liner and an additional support during vacuum service.

# Technical Data

## T4E1

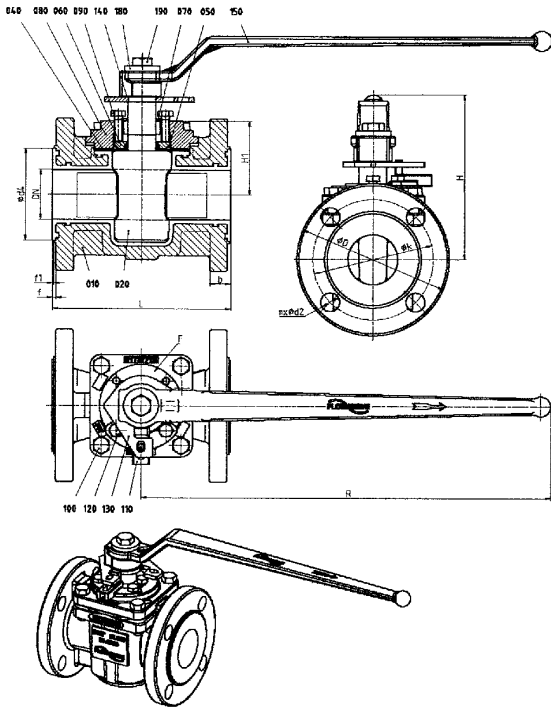

### Parts List T4E1

Item	Qty	Description	Material
010	1	Body	DCI ASTM A395, PFA lined
020	1	Plug	DCI ASTM A395, PFA lined
040	1	Diaphragm	PFA
050*	1	Metal Diaphragm	302 SS
060	1	Thrust Gland	304 SS
070	1	Grounding Spring	302 SS
080	1	Top Cap	DCI ASTM A395
090	2	Adjuster Bolt	ASTM A193 Class B7
100	4	Top Cap Bolt	ASTM A193 Class B7
110	1	Stop	D4 ASTM A351/A744 Grade CF-8M (316 SS)
120	2	Stop Fastener	ASTM A193 Class B7
130	1	Stop Collar	Carbon Steel, Cadmium Plated
140	1	Stop Collar Retainer	302 SS
150	1	Wrench	0.7050, EN-JS1082 (GGG-50)
180	1	Washer	304 SS
190	1	Hexagon Bolt	ASTM A193 Class B7

\* Optional

### Dimensions T4E1 (mm)

DN	L	f1	f	b	H1	H	Ød4	ØD	R	F-Size DIN/ISO 5211	Drilling n Ød2	Øk
1/2"	108	1,5	3	14	53,8	139	36	88,9	260	F05	4 16	60,5
3/4"	117,5	1,5	3	15,5	53,8	139	43	98,6	260	F05	4 16	69,9
1"	127	1,5	3	15,6	53,8	139	51	107,9	260	F05	4 16	79,2
1-1/2"	165	2	4	20	62,9	145	73	127	260	F05	4 16	98,6
2"	178	1,5	3,5	21	73,8	165	92	152,4	410	F07	4 19	120,6
3"	203	1,5	3	25,5	86,4	179	127	190,5	410	F07	4 19	152,4
4"	229	2	4	26,5	106,9	222	157	228,6	674	F10	8 19	190,5
6"	267	2	4	28	141,4	-	208	282	-	F12	8 23	240,5

\* Face-to-Face Dimensions acc. ANSI B16.10  
See page 5 for larger sizes

## T4E2

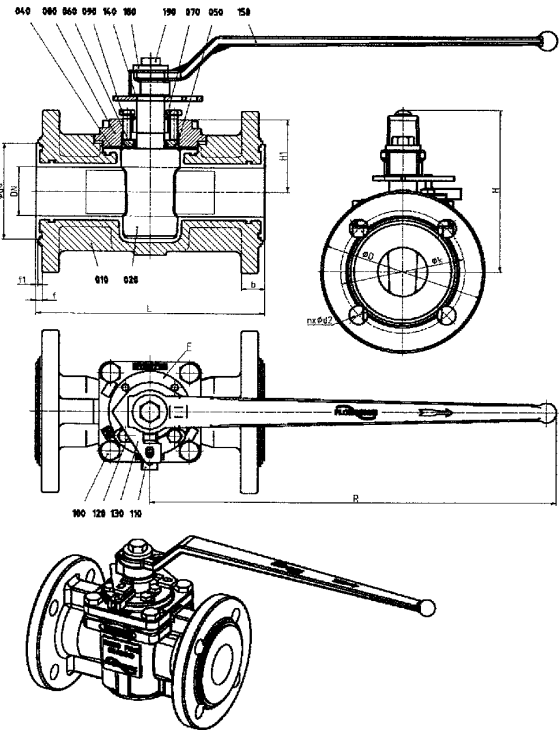

### Parts List T4E2

Item	Qty	Description	Material
010	1	Body	0.7043, EN-JS1049 (GGG-40.3), PFA lined
020	1	Plug	0.7043, EN-JS1049 (GGG-40.3), PFA lined
040	1	Diaphragm	PFA
050*	1	Metal Diaphragm	302 SS
060	1	Thrust Gland	304 SS
070	1	Grounding Spring	302 SS
080	1	Top Cap	0.7043, EN-JS1049 (GGG-40.3)
090	2	Adjuster Bolt	1.4301, X 5 CrNi 18 10
100	4	Top Cap Bolt	1.4301, X 5 CrNi 18 10
110	1	Stop	D4 ASTM A351/A744 Grade CF-8M (316 SS)
120	2	Stop Fastener	1.4301, X 5 CrNi 18 10
130	1	Stop Collar	Carbon Steel, Cadmium Plated
140	1	Stop Collar Retainer	302 SS
150	1	Wrench	0.7050, EN-JS1082 (GGG-50)
180	1	Washer	304 SS
190	1	Hexagon Bolt	1.4301, X 5 CrNi 18 10

\* Optional

### Dimensions T4E2 (mm)

DN	L	f1	f	b	H1	H	Ød4	ØD	R	F-Size DIN/ISO 5211	Drilling n Ød2	Øk
15	130	2	6	18	53,8	139	42	95	260	F05	4 14	65
20	150	5	6	20	53,8	139	56	105	260	F05	4 14	75
25	160	2	6,5	20,5	53,8	139	65	115	260	F05	4 14	85
40	200	2	6,5	21,5	62,9	145	85	150	260	F05	4 19	110
50	230	2	6,5	23,5	73,8	165	98	165	410	F07	4 19	125
80	310	2	7	26	86,4	179	133	200	410	F07	8 19	160
100	350	2	7	28	106,9	222	152	220	674	F10	8 19	180
150*	267	2	4	28	141,4	-	208	282	-	F12	8 23	240,5

\* Face-to-Face Dimensions acc. DIN 3202 F1  
See page 5 for larger sizes

# Technical Data

## T4E3

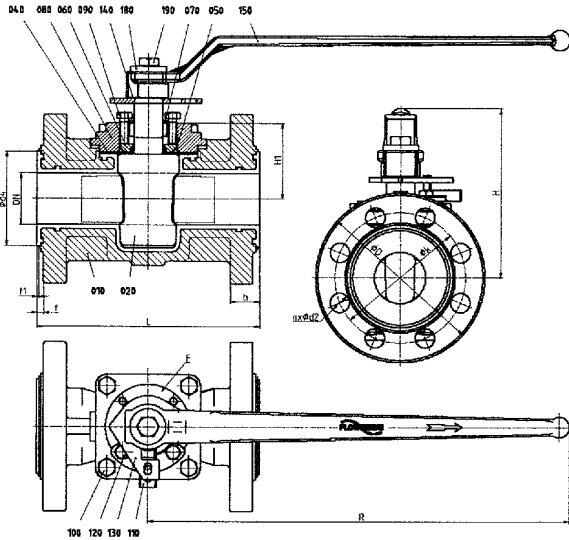

### Parts List T4E3

Item	Qty	Description	Material
010	1	Body	DS ASTM 216 Gr. WCB, PFA lined
020	1	Plug	DCI ASTM A395, PFA lined
040	1	Diaphragm	PFA
050*	1	Metal Diaphragm	302 SS
060	1	Thrust Gland	304 SS
070	1	Grounding Spring	302 SS
080	1	Top Cap	CD4M ASTM A351 Gr CD4MCu
090	2	Adjuster Bolt	ASTM A193 Class B7
100	4	Top Cap Bolt	ASTM A193 Class B7
110	1	Stop	D4 ASTM A351/A744 Grade CF-8M (316 SS)
120	2	Stop Fastener	ASTM A193 Class B7
130	1	Stop Collar	Carbon Steel, Cadmium Plated
140	1	Stop Collar Retainer	302 SS
150	1	Wrench	0.7050, EN-JS1082 (GGG-50)
180	1	Washer	304 SS
190	1	Hexagon Bolt	ASTM A193 Class B7

\* Optional

### Dimensions T4E3 (mm)

DN	L	f1	f	b	H1	H	Ød4	ØD	R	F-Size DN/ISO 5211	Drilling n Ød2	Øk
1/2"	139,5	2	4	17	53,8	139	36	95	260	F05	4 16	66,5
3/4"	152,5	2	6	21,5	53,8	139	43	117,3	260	F05	4 19	82,5
1"	165	2	6,5	22,5	53,8	139	65	123,9	260	F05	4 19	88,9
1-1/2"	190,5	2	6,5	25,5	62,9	145	85	155,4	260	F05	4 22,5	114,3
2"	216	5	6,5	28,5	73,8	165	98	165	410	F07	8 19	127
3"	282,5	2	7	34	86,4	179	133	209,5	410	F07	8 22,5	168
4"	305	2	7	37	106,9	222	152	254	674	F10	8 22,5	200
6"	403,5	2	7	42	141,4	-	208	317,5	-	F12	12 22,5	269,7

\* Face-to-Face Dimensions acc. ANSI B16.10

## T4E1 DN8" - 12" T4E2 DN200 - DN300 T4E3 DN8"

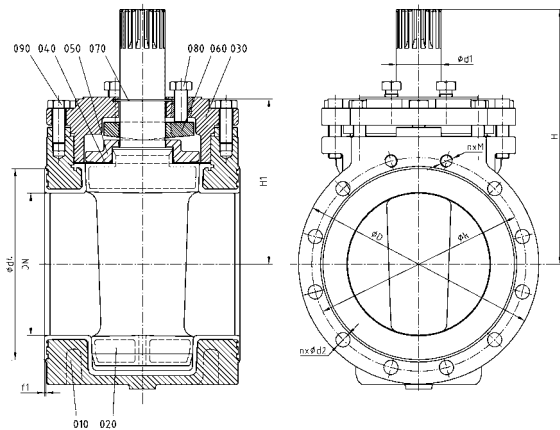

### Dimensions T4E1 DN8" to DN12", 150lbs (mm)

DN	L	f1	f	b	H1	H	Ød4	ØD	Ød1	nxM	Drilling n Ød2	Øk
8"	292,1	2	4	27,5	235,4	362	262	342,9	63,4	2xUNC 3/4"	6 22	298,5
10"	330,2	2	4	37	280,2	431,8	316	406,4	76,2	2xUNC 7/8"	10 25	362
12"	355,6	2	4	40	301,6	454	381	482,6	76,2	2xUNC 7/8"	10 25	431,8

### Dimensions T4E2 DN200 to DN300, PN 10 (mm)

DN	L	f1	f	b	H1	H	Ød4	ØD	Ød1	nxM	Drilling n Ød2	Øk
200	292,1	2	4	27,5	235,4	362	262	342,9	63,4	2xM20	6 22	295
250	330,2	2	4	37	280,2	431,8	316	406,4	76,2	2xM20	10 22	350
300	355,6	2	4	40	301,6	454	381	482,6	76,2	2xM20	10 22	400

### Dimensions T4E3 DN8", 300lbs (mm)

DN	L	f1	f	b	H1	H	Ød4	ØD	Ød1	nxM	Drilling n Ød2	Øk
8"	419	2	4	43	235,4	362	262	381	63,4	-	12 25,4	330,2

### Parts List T4E1 DN8" to 12" and T4E2 DN200 to DN300

Item	Qty	Description	Material
010	1	Body	DCI ASTM A395, PFA lined
020	1	Plug	CD4M ASTM A351 Gr CD4MCu, PFA lined
030	1	Top Cap	DCI ASTM A395
040	1	Diaphragm	PFA
050	1	Thrust Gland	CD4M ASTM A351 Gr CD4MCu
060	1	Adjuster	CD4M ASTM A351 Gr CD4MCu
070	1	Grounding Spring	302 SS
080	1 set	Adjuster Bolt	Stainless Steel
090	1 set	Hexagon Bolt	Stainless Steel

Other materials available on request

### Parts List T4E3 DN8"

Item	Qty	Description	Material
010	1	Body	DS ASTM A216 Gr WCB, PFA lined
020	1	Plug	CD4M ASTM A351 Gr CD4MCu, PFA lined
030	1	Top Cap	CD4M ASTM A351 Gr CD4MCu, PFA lined
040	1	Diaphragm	PFA
050	1	Thrust Gland	CD4M ASTM A351 Gr CD4MCu
060	1	Adjuster	CD4M ASTM A351 Gr CD4MCu
070	1	Grounding Spring	302 SS
080	1 set	Adjuster Bolt	Class 8.8 (Metric)
090	1 set	Hexagon Bolt	Class 8.8 (Metric)

Other materials available on request

*Flowserve has the answer to your corrosion resistant, quarter-turn valving needs.*

*Clockwise from top right.*

**Durco® BTV-2000**

PTFE or UHMWPE lined chemical service valve

**Atomac®**

Lined ball valves

- ASME/ISO, standard and full port
- Specialty valves
- Valve products and accessories

**Durco® SleeveLine®**

Non-lubricated, PTFE-sleeved plug valves

- G4 Isolation
- G4E – DIN Mounting Pad
- G4 Marathon™
- TSG4 Severe Service

**Flowserve Durco® T4E-Line®**

Non-lubricated, PFA-lined plug valves

**Big Max® Butterfly**

High performance valves

**Durco® Microfinish™**

Alloy ball valves

**Automax®**

Valve automation systems

- Actuators
- Controls with smart technology
- Accessories



Quality System Certificate

For more information, contact:



Flowserve Ahaus GmbH  
 Von Braun Strasse 19a  
 D-48683 Ahaus  
 Germany  
 Phone: + 49.2561.686.0  
 Fax: + 49.2561.686200  
 www.flowserve.com

Bulletin FCD DVAB0001-00 (E/A4)  
 Printed in U.S.A.  
 October 2004  
 © Flowserve Corporation