

# *FLOW+* Ball Valves



**Quality Valves at Low Cost**

**B Series 1, 2, 3 PC Ball Valves**

B01: 2 PC, 1000 WOG, 316SS .....2  
 B02: 2 PC, 2000/1500 WOG, 316SS .....2  
 B03: 2 PC, 1000 WOG, 316SS Direct Mount .....3  
 B04: 3 PC, 1000 WOG, 316SS, Screwed Ends .....3  
 B04S: 3 PC, 1000 WOG, 316SS, Socket Weld Ends.....3  
 B05: 3 PC, 1000 WOG, 316SS, Direct Mount, Screwed Ends .....4  
 B05S: 3 PC, 1000 WOG, 316SS, Direct Mount, Socket Weld Ends .....4  
 B06: 1 PC, 2000 WOG, A108, Bar Stock Carbon Steel .....4  
 B07L: 3 PC, 1000 WOG, 316SS, 3 way, L-port .....5  
 B07T: 3 PC, 1000 WOG, 316SS, 3 way, T-port .....5  
 B11: 2 PC, 2000/1500 WOG, Carbon Steel .....5

**Z Series Floating Flanged Ball Valves**

Z Series Part Numbering System .....6  
 Pressure & Temperature Charts .....6  
 150# RF Flanged  
     ZF1 Full Port Direct Mount SS .....7  
     ZF1 Full Port Carbon Steel & Low Temp .....8  
     ZR1 Reg Port Carbon Steel & Low Temp .....9  
 300# RF Flanged  
     ZF3 Full Port Carbon Steel, Low Temp & SS .....10  
     ZR3 Reg Port Carbon Steel & Low Temp .....11  
 600# RF Flanged  
     ZF6 Full Port Carbon Steel & Low Temp .....12  
     ZR6 Reg Port Carbon Steel & Low Temp .....13

**Additional Information**

Automation .....14  
 Terms and Conditions .....15



# 2-PC Full Port SS Ball Valve

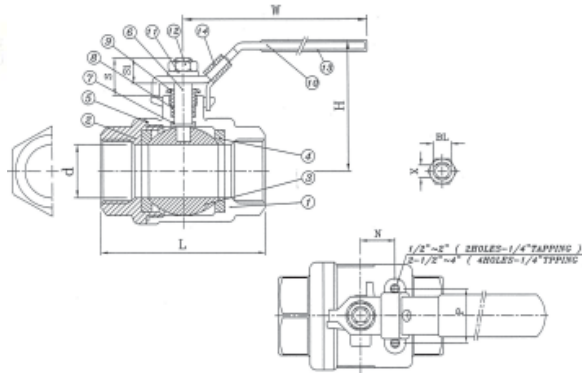

No	Parts for B01	Qty	Material
01	Body	1	ASTM-CF8M-A351
02	End Cap	1	ASTM-CF8M-A351
03	Ball	1	ASTM-CF8M-A351
04	Ball Seat	2	15% R-PTFE
05	Joint Gasket	1	PTFE
06	Stem	1	AISI 316
07	Thrust Washer	1	PTFE
08	Stem Packing	2	PTFE
09	Gland Nut	1	AISI 304
10	Handle	1	AISI 304
11	Spring Washer	1	AISI 304
12	Stem Nut	1	AISI 304
13	Handle Sleeve	1	Vinyl Grip
14	Lock Device	1	AISI 304

**Pressure rating:**  
 - 1000 psi (69 Bar)  
 WOG for 1/4" to 2"

- Features:
- Investment Cast Body and Cap
  - Blow-out proof stem / Full Port
  - FNPT threaded on both ends
  - Material: ASTM A351-CF8M
  - Locking Handle

Size	dia (mm)	L	H	W	S	S1	X	N	P	BL	Cv Factor	Wt kg
1/4"	11.6	44.5	51	95	16.8	10.2	5	12.5	25	5/16"	7	0.21
3/8"	12.7	44.5	51	95	16.8	10.2	5	12.5	25	5/16"	7	0.22
1/2"	15	57	53	95	16.8	10.2	5	12.5	25	5/16"	15	0.29
3/4"	20	65	59.5	110	21	13.5	6.5	21	24	3/8"	45	0.42
1"	25.4	76	73	135	24	16	8	22.5	33.5	7/16"	65	0.71
1-1/4"	32	87.5	79	135	25	16	8	23.5	38.1	7/16"	125	1.06
1-1/2"	38	102	90.5	165	26.5	17	9	23.5	38.1	1/2"	175	1.68
2"	50.8	123	98.5	165	26.5	17	9	23.5	38.1	1/2"	380	2.71

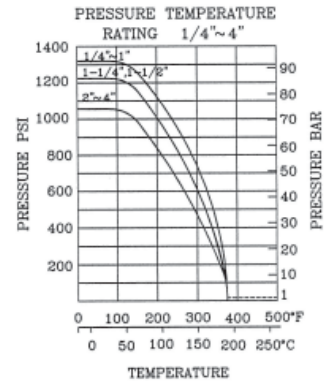

# 2-PC Full Port SS Ball Valve

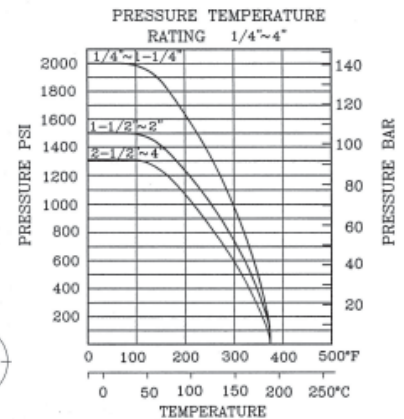
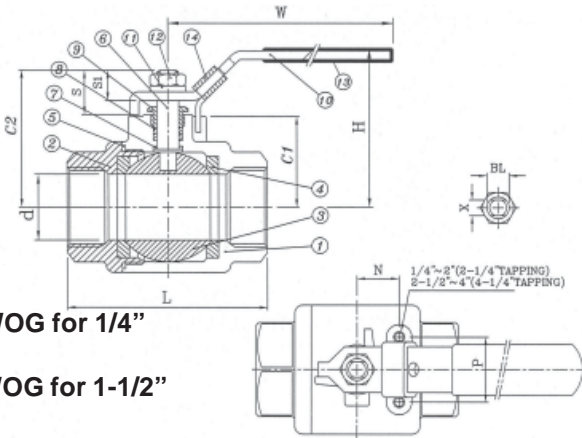

**Pressure rating:**  
 - 2000 psi (137.8 Bar) WOG for 1/4" to 1-1/4"  
 - 1500 psi (103.4 Bar) WOG for 1-1/2" to 2"  
 - 1300 psi (89.6 Bar) WOG for 2-1/2" to 4"

- Features:
- Investment Cast Body and Cap
  - Blow-out proof stem / Full Port
  - FNPT threaded on both ends
  - Locking Handle
  - Material: ASTM A351-CF8M

Size	dia (mm)	L	H	W	S	S1	X	N	P	C1	C2	BL	Cv Factor	Wt (kg)
1/4"	11.6	60.5	53	105	16.5	10.2	5	12.5	28.5	26	42.5	5/16"	7	0.3
3/8"	12.7	60.5	53	105	16.5	10.2	5	12.5	28.5	26	42.5	5/16"	7	0.3
1/2"	15	62.5	53	105	16.5	10.2	5	12.5	28.5	26	42.5	5/16"	15	0.35
3/4"	20	77	60	125	20	13.5	6.5	21	34.8	32.2	52.3	3/8"	45	0.58
1"	25.4	90	74	160	23.5	16	8	22.5	34.8	39.2	63.1	7/16"	65	1.04
1-1/4"	32	100	80	160	23.5	16	8	23.5	38.1	45.3	68.7	7/16"	125	1.54
1-1/2"	38	118	92	190	25.5	17	9	23.5	38.1	53.4	78.9	1/2"	175	2.3
2"	50.8	138	101	190	25.5	17	9	34	38.1	62.6	88.2	1/2"	380	3.8

No	Parts for B02	Qty	Material
01	Body	1	ASTM-CF8M-A351
02	End Cap	1	ASTM-CF8M-A351
03	Ball	1	ASTM-CF8M-A351
04	Ball Seat	2	15% R-PTFE
05	Joint Gasket	1	PTFE
06	Stem	1	AISI 316
07	Thrust Washer	1	PTFE
08	Stem Packing	2	PTFE
09	Gland Nut	1	AISI 304
10	Handle	1	AISI 304
11	Spring Washer	1	AISI 304
12	Stem Nut	1	AISI 304
13	Handle Sleeve	1	Vinyl Grip
14	Lock Device	1	AISI 304

*\*Note: available in Carbon Steel as model B11 on page*

Sizes and Specifications shown are subject to change without notice.

# 2-PC Full Port SS Ball Valve - Direct Mount\*



\* See Page 14 for Actuation

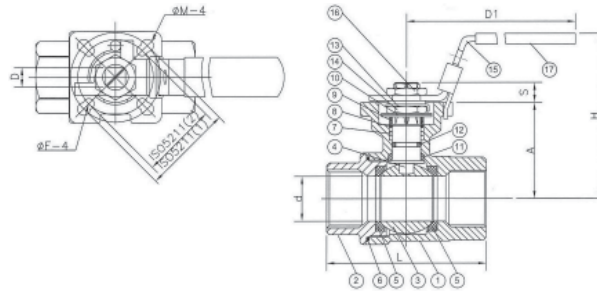

No	Parts	Material
01	Body	ASTM-A351Gr.CF8M
02	End Cap	ASTM-A351Gr.CF8M
03	Ball	ASTM-A351Gr.CF8M
04	Stem	S.S. 316
05	Ball Seat	15% RTFE
06	Gasket	15% RTFE
07	Stem Packing	15% RTFE
08	Thrust Washer	15% RTFE
09	Stem Packing	S.S. 304
10	Belleville Washer	SUS 304-USP
11	Thrust Washer	PTFE + 25% Carbon
12	O-ring	Viton
13	Locking Washer	S. S. 304
14	Stem Nut	S.S. 304
15	Handle	S.S. 304
16	Handle Nut	S.S. 304
17	Handle Cover	Vinyl Grip

**Pressure rating: 1000 psi (69 Bar)  
WOG for 1/4" to 2"**

High Cycle, Live Loaded, Triple Stem Seal comprising of:

- Carbon Filled PTFE Wedge Ring Thrust Washer
- Viton O-Ring
- 15% RTFE Chevron packing
- Live loaded Belleville Washers
- Packing Nut Mechanically Locked to Stem

Features:

- Investment Cast body and cap
- Blow-out proof stem / Full port
- Direct Mounting Pad for ISO Std 5211
- FNPT threaded on both ends
- Material: ASTM A351-CF8M (316SS)

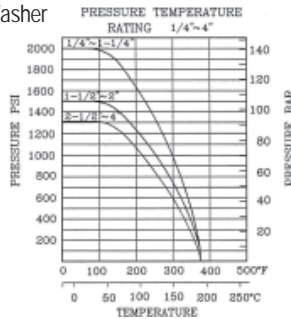

Size	dia (mm)	L	F	M	ISO 5211	Torque in - lb	D	H	D1	S	A	Cv	Wt (kg)
1/2"	15	65.3	6	7.5	42	85	9	72.85	112	8.5	36.95	15	0.46
					F04								
3/4"	20	77.3	7.5	9.5	50	110	9	81.8	112	8.5	45	45	0.81
					F05								
1"	25	88.7	7.5	9.5	50	180	11	90.45	136	11.4	53.45	65	0.96
					F05								
1-1/2"	38	109	7.5	9.5	50	315	14	114.7	197.9	14	74.75	175	2.3
					F05								
2"	50	125.3	9.5	11	70	450	14	124.0	197.9	13.7	83.5	380	3.2
					F07								

# 3-PC Full Port SS Ball Valve

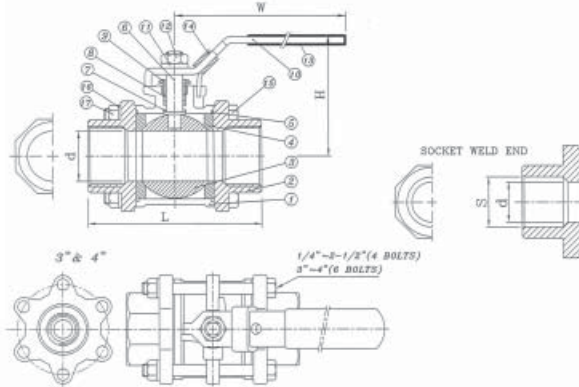

No	Parts	Qty	Material
01	Body	1	ASTM-CF8M-A351
02	End Cap	1	ASTM-CF8M-A351
03	Ball	1	ASTM-CF8M-A351
04	Ball Seat	2	15% R-PTFE
05	Joint Gasket	1	15% R-PTFE
06	Stem	1	AISI 316
07	Thrust Washer	1	PTFE
08	Stem Packing	2	PTFE
09	Gland Nut	1	AISI 304
10	Handle	1	AISI 304
11	Stem Washer	1	AISI 304
12	Stem Nut	1	AISI 304
13	Handle Sleeve	1	Vinyl Grip
14	Lock Device	1	AISI 304
15	Bolt	4-6	AISI 304
16	Spring Washer	4-12	AISI 304
17	Hex Nut	4-12	AISI 304

**Pressure rating: 1000 psi (69 Bar) WOG for 1/4" to 4"**

Features:

- Investment Cast body and cap
- Blow-out proof stem/Full port
- FNPT threaded on both ends for B04
- Socket Weld on both ends for B04S
- Locking Handle
- Material: ASTM A351-CF8M (316SS)

Size	dia (mm)	L	H	W	B	D	S	Cv Factor	Wt
1/4"	11.6	54	51	95	12	18	14.1	10	0.34
3/8"	12.7	54	51	95	12.5	18	17.6	10	0.34
1/2"	15	61.5	55	95	15.8	22	21.7	26	0.46
3/4"	20	71	58.5	110	20.9	28	27.2	50	0.62
1"	25	83.5	73	135	26.6	34	33.9	68	1.96
1-1/4"	32	97	78.5	135	35.05	44	42.6	120	1.49
1-1/2"	38	110.5	90.5	165	40.9	50	48.7	170	2
2"	50	129	99	165	52.5	61.5	61.1	360	3.12
2-1/2"	65	171.5	127	215	69	76	76.9	510	6.5
3"	80	200	136	215	82	90	89.8	900	10.4
4"	100	252	172	325	106	115	115.4	1250	20.2

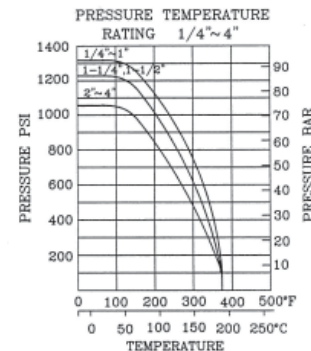

# 3-PC Full Port SS Ball Valve - Direct Mount\*



\* See page 14 for Actuation

Available in Threaded (B05), Socket weld (B05S), and Tri-Clamp (B05TC) ends

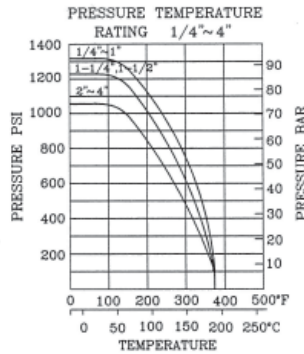
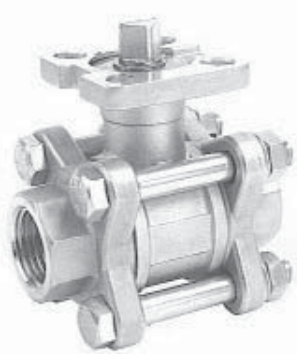

Size	dia (mm)	L	F	M	ISO 5211	Torque in - lbs	D	H	D1	S	A	Cv	Wt (kg)	
1/2"	15	63.5	6	7.5	42	50	85	9	72.85	112	8.5	36.95	26	0.6
					F04	F05								
3/4"	20	72.5	7.5	9.5	50	70	110	9	80.8	112	8.5	45	50	0.7
					F05	F07								
1"	25	81	7.5	9.5	50	70	180	11	90.45	136	11.4	53.45	68	1.03
1-1/2"	38	108	7.5	9.5	50	70	315	14	115.25	197.9	14	74.75	170	2.5
					F05	F07								
2"	50	121.5	9.5	11	70	102	450	14	124.0	197.9	13.7	83.5	360	3.4
					F07	F10								
3"	80	190	11	14.3	102	125	680	17	208.5	264	18	118.25	900	11.2
					F10	F12								
4"	100	225	11	14.3	102	125	1190	22	216.7	325	23	153.75	1250	22
					F10	F12								

Pressure rating: 1000 psi (69 Bar) WOG for 1/4" to 4"

High Cycle, Live Loaded, Triple Stem Seal comprising of:

- Carbon Filled PTFE Wedge Ring Thrust Washer and Viton O-Ring
- 15% RTFE Chevron packing
- Live loaded Belleville Washers
- Packing Nut Mechanically Locked to Stem

Features:

- Investment Cast body and cap
- Blow-out proof stem / Full port
- Direct Mounting Pad for ISO Std 5211
- FNPT threaded on both ends on B05
- Socket weld ends on B05S
- Tri-Clamp ends on B05TC
- Material: ASTM A351-CF8M (316SS) and 316LSS Caps on Socket Weld

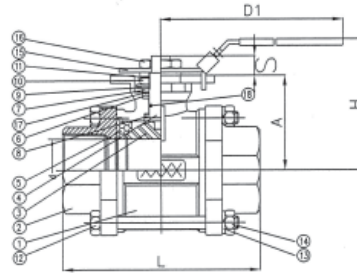
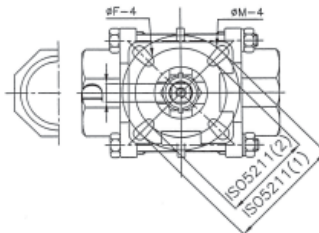

No	Parts	Qty	Material
01	Body	1	ASTM-A351 Gr.CF8M
02	End Cap	2	ASTM-A351 Gr.CF8M
03	Ball	1	ASTM-A351 Gr.CF8M
04	Stem	1	AISI 316
05	Seat	2	15% RTFE
06	Stem Packing	1	15% RTFE
07	Gland Nut	1	AISI 304
08	Thrust Washer	1	PTFE + 25% Carbon
09	Belleville Washer	2	SUS 304-CSP
10	Stem Nut	1	S.S. 304
11	Spring Washer	1	S.S. 304
12	Bolt	4 - 6	S.S. 304
13	Bolt Washers	4 - 6	S.S. 304
14	Bolt Nuts	4 - 6	S.S. 304
15	Handle	1	S.S. 304
16	Handle Nut	1	S.S. 304
17	Stem Ring	1	PTFE + 25% Carbon
18	O-Ring	1	Viton

# 1-PC Reg Port Carbon Steel Ball Valve

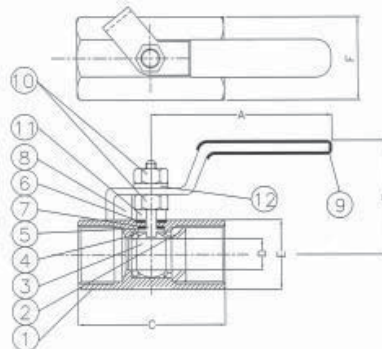

No	Parts for B06	Material (Carbon)
01	Body	A108
02	Insert	A108
03	Ball	AISI 316
04	Seat	PTFE+15%G/F
05	Stem	AISI 316
06	Thrust Washer	PTFE
07	Stem Seal	PTFE
08	Handle	AISI 304
09	Handle Sleeve	Vinyl Grip
10	Nut	304 Stainless Steel
11	Washer	WCB
12	Spring Washer	304 Stainless Steel

Pressure rating: 2000 psi (138 Bar)

Features:

- NACE Trim
- Blow-out proof stem
- FNPT threaded on both ends
- Body material: ASTMA108 Carbon Steel

Size	A	B	C	D	E	F	Wt (kg)	Cv
1/4"	61	29.5	41.3	5	21	24.1	0.21	1.5
3/8"	79	34.5	44	7.2	23	26.4	0.22	3.5
1/2"	108	63	57.2	9.0	29	33.3	0.29	5.7
3/4"	110	65	65.1	12.5	35	40.3	0.42	10
1"	122	68	71	15	41	47.2	0.71	16
1-1/4"	145	79.5	92.1	20	55	63.4	1.06	25
1-1/2"	148	84	98.4	25	57	65.7	1.68	40
2"	148	92.5	114.3	32	73.5	84.7	2.71	62

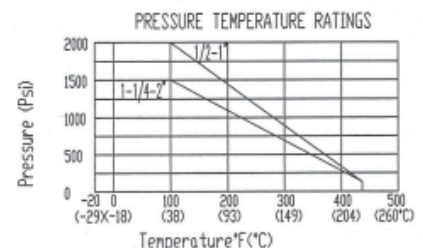

# 3-way Reg. Port SS Ball Valve - Direct Mount\* **Flow+** B07L/T

\* See page 14 for Actuation

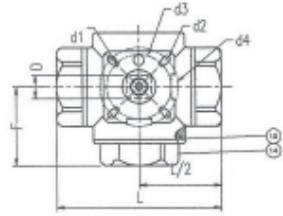
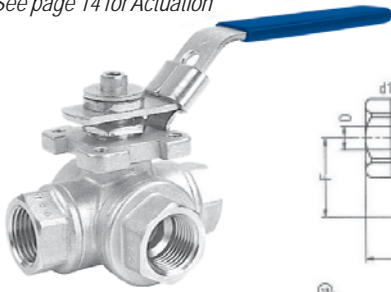

Size	dia (mm)	L	F	ISO 5211	D	H	D1	A	C	d1	d2	H1	W (kg)	Cv
1/2"	12.7	75.7	37.25	42	9	77.45	112	8.5	12	6	7.5	40.65	0.67	6
				50										
3/4"	16.0	86.6	44.7	F04	9	82	112	8.5	12	7.5	9.5	45.2	1.07	8
				F05										
1"	20.0	102.4	51.4	F06	11	93.7	136.5	11.4	15.8	7.5	9.5	56.5	1.68	11
				F07										
1-1/2"	32.0	125.8	62.7	F08	14	120.25	197.5	14	20.8	7.5	9.5	73.5	3.6	65
				F09										
2"	38.1	149	74.6	F10	14	129.85	197.5	13.7	20.8	9.5	11	87.35	5.8	112
				F11										

- Pressure rating: 1000 psi (69 Bar) WOG for 1/4" to 2"**  
 High Cycle, Live Loaded, Triple Stem Seal comprising of:
- Carbon Filled PTFE Wedge Ring Thrust Washer
  - Viton O-Ring
  - 15% RTFE Chevron packing
  - Live loaded Belleville Washers
  - Packing Nut Mechanically Locked to Stem

- Features:**
- Anti-static device, L-port, T-port
  - Blow-out proof stem
  - FNPT end connections
  - Locking Handle
  - Material: ASTM A351 GR.CF8M (316SS)

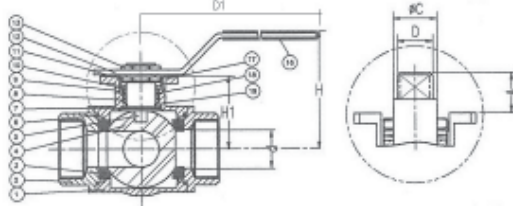

POSITION TYPE	1	2	3	4
L	1 ⊕ <sub>2</sub> 3	1 ⊕ <sub>2</sub> 3		
T	1 ⊕ <sub>2</sub> 3	1 ⊕ <sub>2</sub> 3	1 ⊕ <sub>2</sub> 3	1 ⊕ <sub>2</sub> 3

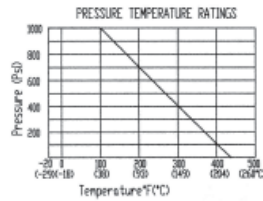

No	Parts	Material
01	Body	ASTM-A351GR.CF8M
02	End Cap	ASTM-A351GR.CF8M
03	Seat	15% RTFE
04	Ball	ASTM-A351GR.CF8M
05	Stem	S. S. 316
06	Gasket	15% RTFE
07	Thrust Washer	PTFE + 25% Carbon
08	Stem Packing	15% RTFE
09	Gland	S.S. 304
10	Belleville Washer	SUS 304-CSP
11	Stem Nut	S. S. 304
12	Handle	S. S. 304
13	Handle Nut	S. S. 304
14	End Cap	ASTM A351 GR.CF8M
15	Gasket	15% RTFE
16	Handle Sleeve	Vinyl Grip
17	Locking Washer	SUS 304-CSP
18	Thrust Washer	PTFE+25% G/F
19	O-Ring	Viton

# 2-PC Full Port Carbon Steel Ball Valve **Flow+** B11



Size	dia (mm)	L	H	W	S	S1	X	N	P	C1	C2	BL	Cv Factor	Wt (kg)
1/4"	11.6	60.5	53	105	16.5	10.2	5	12.5	28.5	26	42.5	5/16"	7	0.3
3/8"	12.7	60.5	53	105	16.5	10.2	5	12.5	28.5	26	42.5	5/16"	7	0.3
1/2"	15	62.5	53	105	16.5	10.2	5	12.5	28.5	26	42.5	5/16"	15	0.35
3/4"	20	77	60	125	20	13.5	6.5	21	34.8	32.2	52.3	3/8"	45	0.58
1"	25.4	90	74	160	23.5	16	8	22.5	34.8	39.2	63.1	7/16"	65	1.04
1-1/4"	32	100	80	160	23.5	16	8	23.5	38.1	45.3	68.7	7/16"	125	1.54
1-1/2"	38	118	92	190	25.5	17	9	23.5	38.1	53.4	78.9	1/2"	175	2.3
2"	50.8	138	101	190	25.5	17	9	34	38.1	62.6	88.2	1/2"	380	3.8
2-1/2"	65	167	130	245	41	29.5	12	35	56	77	118.8	3/4"	500	6.8
3"	80	193	142	245	41	29.5	12	35	56	88.8	130.3	3/4"	900	11.6
4"	100	260	174	325	48	36.5	16	50	63	109.6	158.8	1"	1250	23

- Pressure rating:**
- 2000 psi (137.8 Bar) WOG for 1/4" to 1-1/4"
  - 1500 psi (103.4 Bar) WOG for 1-1/2" to 3"

- Features:**
- Carbon Steel Body and Cap
  - Material: ASTMA216-WCB
  - Blow-out proof stem / Full Port
  - FNPT threaded on both ends
  - Locking Handle

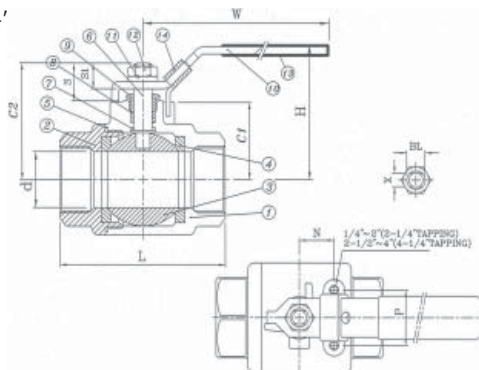

No	Parts for B11	Qty	Material
01	Body	1	ASTM-A216-WCB
02	End Cap	1	ASTM-A216-WCB
03	Ball	1	ASTM-CF8M-A351
04	Ball Seat	2	15% R-PTFE
05	Joint Gasket	1	PTFE
06	Stem	1	AISI 316
07	Thrust Washer	1	15% RTFE
08	Stem Packing	2	15% RTFE
09	Gland Nut	1	AISI 304
10	Handle	1	AISI 304
11	Spring Washer	1	AISI 304
12	Stem Nut	1	AISI 304
13	Handle Sleeve	1	Vinyl Grip
14	Lock Device	1	AISI 304

# Z Series Valve Part Numbering System

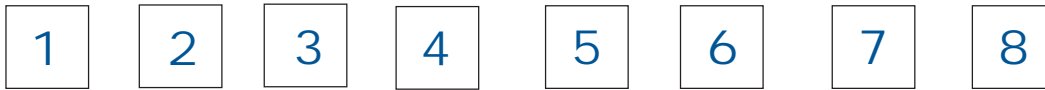

## 1 = Code & Class

ZR1 = Reduced port class 150  
 ZR3 = Reduced port class 300  
 ZR6 = Reduced port class 600  
 ZF1 = Full port class 150  
 ZF3 = Full port class 300  
 ZF6 = Full port class 600

## 2 = Size

050 = 1/2"  
 075 = 3/4"  
 001 = 1"  
 150 = 1-1/2"  
 002 = 2"  
 250 = 2-1/2"  
 003 = 3"  
 004 = 4"  
 006 = 6"  
 008 = 8"

## 3 = Type

A = Floating ball split body  
 B = Floating ball unibody

## 4 = Body Material

1 = ASTM A216 WCB  
 2 = ASTM A352 LCC  
 3 = ASTM A351 CF8M  
 4 = A105 C.S.  
 5 = A350 LF2

## 5 = End Connection

F = Raised face flanged \*  
 R = Ring joint flanged ends  
 B = Butt-welded ends

## 6 = Trim Material

1 = C.S. - ENP  
 2 = 304SS  
 3 = 316SS \*

## 7 = Seat material

P = PTFE  
 R = RTFE \*  
 N = Nylon  
 K = Peek  
 D = Devlon

## 8 = Operator

H = Handle/Lever  
 G = Gear Operator  
 X = Bare Stem

\* Denotes standard stock trim



# Z Series Pressure & Temperature Charts



## 150# & 300#

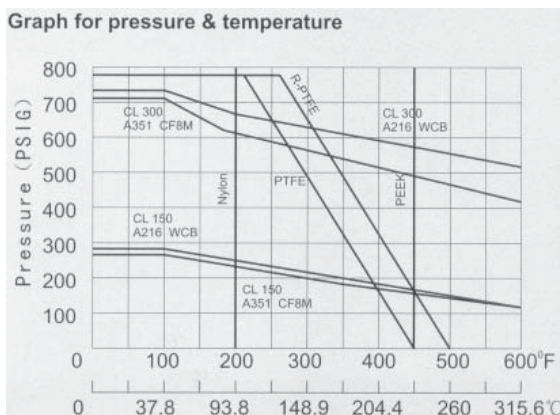

## 600#

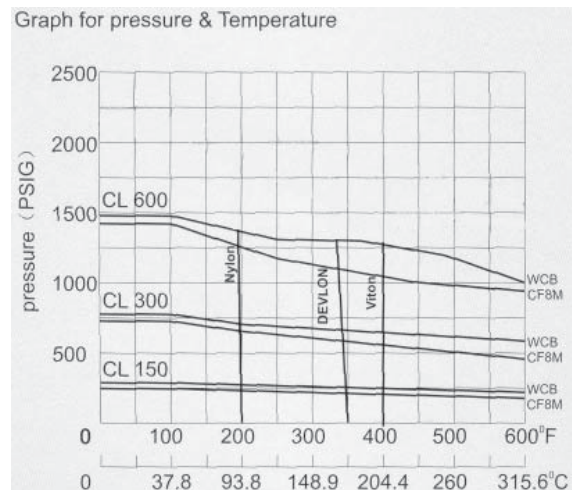

# 150# Full Port Direct Mount SS

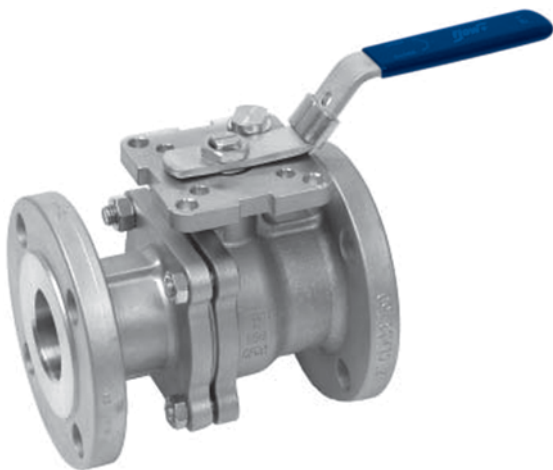

### Features:

- Full bore, 2 piece body floating ball
- ISO Mounting Pad, direct mounting to actuator
- Fire-safe design, blow-out proof stem
- Cavity relieving seats, anti-static device
- Designed according to ASME/ANSI Class 150 - B16.34
- Face to Face per ASME/ANSI B16.10 Long Pattern
- Flanges designed per ASME/ANSI B16.5
- NACE MR0175
- Design Standard per API 608
- Markings per MSS-SP25
- Pressure Test per API 598
- Lever operated

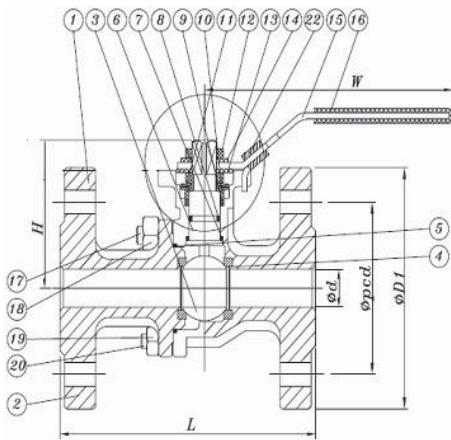

No.	Part Name	Material
1	Body	A351 CF8M
2	End	A351 CF8M
3	Ball	A182 F316
4	Seat	R-PTFE
5	Body Gasket	R-PTFE
6	Stem	AISI 316
7	Trust Washer	R-PTFE
8	O-Ring	VITON
9	Stem Packing	Graphite / R-PTFE
10	Stem Ring	AISI 304SS
11	Belleville Washer	AISI 304SS
12	Stem Nut	AISI 304SS
13	Lock Washer	AISI 304SS
14	Spring Washer	AISI 304SS
15	Handle	AISI 304SS
16	Handle Sleeve	Plastic
17	Nut 1	AISI 304SS
18	Stud Bolt 1	AISI 304SS
19	Nut 2	AISI 304SS
20	Stud Bolt 2	AISI 304SS
21	Stopper Pin	AISI 304SS
22	Lock Device	AISI 304SS

Size	d	D1	Pcd	L	H	W	Torque	WT	Cv
1/2"	0.59"	3.5"	2.38"	4.25"	2.16"	4.3"	85 in lb	3.6 lb	27
12	15	89	60.5	108	55	110	9.6 Nm	1.6 kg	
3/4"	0.79"	3.875"	2.75"	4.6"	2.36"	4.3"	110 in lb	4.5 lb	50
20	20	98	70	117	60	110	12.4 Nm	2 kg	
1"	0.98"	4.25"	3.125"	5"	2.71"	5.35"	180 in lb	7 lb	95
25	25	108	79.5	127	68.9	136	20.3 Nm	3.2 kg	
1-1/2"	1.57"	5"	3.875"	6.5"	3.56"	8"	315 in lb	14 lb	280
38	40	127	98.5	165	90.5	203	35.6 Nm	6.4 kg	
2"	1.97"	6"	4.75"	7"	3.82"	8"	450 in lb	21 lb	490
50	50	152.4	120.5	178	97.2	203	50.8 Nm	9.5 kg	
3"	3.14"	7.5"	6"	8"	5.8"	10.9"	680 in lb	48 lb	1160
75	80	190.5	152.5	203	147.5	277.5	76.8 Nm	22 kg	
4"	3.94"	9"	7.5"	9.02"	6.61"	14.86"	1190 in lb	79 lb	2200
100	100	229	190.5	229	168	377.5	134.5 Nm	36 kg	
6"	5.9"	11"	9.5"	15.51"	9.45"	24"	2850 in lb	207 lb	5100
150	150	279	241.5	394	240	600	322 Nm	94 kg	

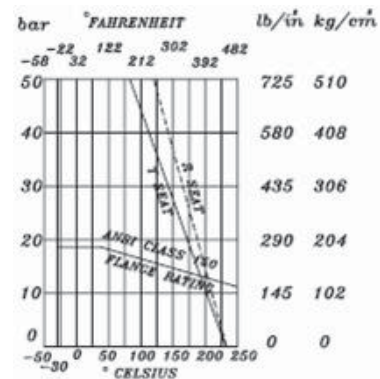



**Features:**

- Full bore, 2 piece body floating ball
- ISO Mounting Pad
- Fire-safe to API-607, 4th Ed., blow-out proof stem
- Cavity relieving seats, anti-static device
- Designed according to ASME/ANSI Class 150 - B16.34
- Face to Face per ASME/ANSI B16.10 Long Pattern
- Flanges designed per ASME/ANSI B16.5
- NACE MR0175
- Design Standard per API 608
- Markings per MSS-SP25
- Pressure Test per API 598
- Lever operated 2"-6", Gear operated 8"

L  
E  
V  
E  
R

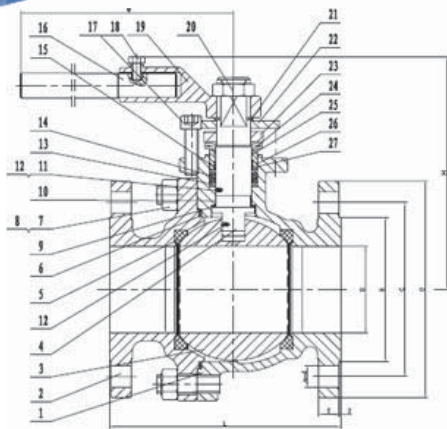

No	Part Name	WCB Body	LCC Body
1	Body	A216 WCB	A352 LCC
2	End	A216 WCB	A352 LCC
3	Ball	A182 F316	A182 F316
4	Stem	A182 F316	A182 F316
5	Seat	R-PTFE	R-PTFE
6	Body Gasket	304 Graphite Spiral Wound	304 Graphite Spiral Wound
7	Nut	A194-2HM	A194-2HM
8	Full Threaded Bolt	A193-B7M	A320 L7M
9	Stem Gasket	PTFE	PTFE
10	Stem Bearing	PTFE	PTFE
11	Steel Ball	A276 304	A276 304
12	Antistatic Spring	A276 304	A276 304
13	Stem Firesafe Gasket I	Flexible Graphite + 316	Flexible Graphite + 316
14	Stem Firesafe Gasket II	Flexible Graphite	Flexible Graphite
15	Packing Gland Bearing	PTFE	PTFE
16	Lever	AISI 1020	AISI 1020
17	Screw	A193-B7M	A320 L7M
18	Hex Bolt	A193-B7M	SS
19	Joint	A216 WCB	A352 LCC
20	Nut	AISI 1020	AISI 1020
21	Axial Retaining Ring	AISI 1566	AISI 1566
22	Limit Block	A36	A36
23	Nut	AISI 1020	AISI 1020
24	Belleville Washer	A276 304	A276 304
25	O-Ring	Viton	Viton
26	O-Ring	Viton	Viton
27	Packing Bushing	A276 316	A276 316

G  
E  
A  
R

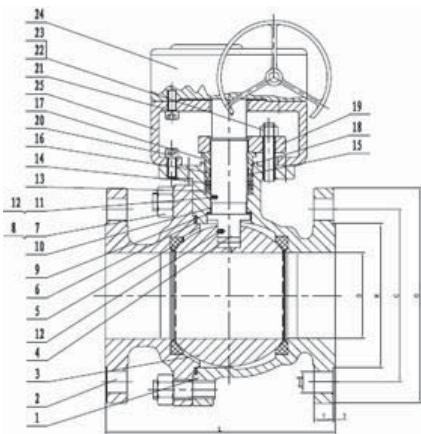

No	Part Name	WCB Body	LCC Body
1	Body	A216 WCB	A352 LCC
2	End	A216 WCB	A352 LCC
3	Ball	A182 F316	A182 F316
4	Stem	A182 F316	A182 F316
5	Seat	R-PTFE	R-PTFE
6	Body Gasket	304 Graphite Spiral Wound	304 Graphite Spiral Wound
7	Nut	A194-2HM	A194-2HM
8	Full Threaded Bolt	A193-B7M	A320 L7M
9	Stem Gasket	PTFE	PTFE
10	Stem Bearing	PTFE	PTFE
11	Steel Ball	A276 304	A276 304
12	Antistatic Spring	A276 304	A276 304
13	Stem Firesafe Gasket I	Flexible Graphite + 316	Flexible Graphite + 316
14	Stem Firesafe Gasket II	Flexible Graphite	Flexible Graphite
15	Packing Gland Bearing	PTFE	PTFE
16	O-Ring	Viton	Viton
17	O-Ring	Viton	Viton
18	Packing Bushing	A276 316	A276 316
19	Packing Plate	A216 WCB	A352 LCC
20	Inner Hex Screw	A193-B7M	A320 L7M
21	Inner Hex Screw	A194-B7M	A320 L7M
22	Nut	A194-2HM	A194 7M
23	Bolt	A193-B7M	A320 L7M
24	Actuator	Component	Component
25	Yoke	A36	A36

Size	L	D	R	C	O	n-d	T	W	H	WT	Torque		Cv
											150 PSI	285 PSI	
2"	7"	1.97"	3.625"	4.75"	5.9"	4-3/4"	0.562"	9.53"	6.14"	22	372 in lbs	620 in lbs	450
50	178	50	92.1	120.7	150	4-19	14.3	242	156	9.8	42 Nm	70 Nm	
3"	8"	2.95"	5"	6"	7.48"	4-3/4"	0.69"	13.78"	8.07"	44	797 in lbs	1328 in lbs	1100
76	203	75	127	152.4	190	4-19	17.5	350	205	20	90 Nm	150 Nm	
4"	9.02"	3.98"	6.19"	7.5"	9.05"	8-3/4"	0.88"	18.11"	8.858"	77	1328 in lbs	2168 in lbs	2200
102	229	101	157.2	190.5	230	8-19	22.3	460	225	35	150 Nm	245 Nm	
6"	15.51"	5.94"	8.5"	9.5"	11.02"	8-.885"	0.94"	29.53"	12.48"	211	3009 in lbs	4956 in lbs	5200
152	394	151	215.9	241.3	280	8-22.5	23.9	750	317	96	340 Nm	560 Nm	
8"	18"	7.95"	10.625"	11.75"	13.58"	8-.885"	1.06"			364	7213 in lbs	12001 in lbs	10,000
203	457	202	269.9	298.5	345	8-22.5	27			165	815 Nm	1356 Nm	

# 150# Reg. Port Carbon Steel & Low Temp

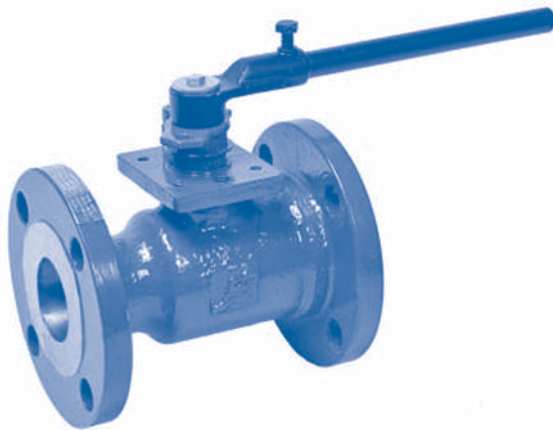

### Features:

- Reduced bore, 1 piece unibody floating ball
- ISO Mounting Pad
- Fire-safe to API-607 4th Ed., blow-out proof stem
- Cavity relieving seats, anti-static device
- Designed according to ASME/ANSI Class 150 - B16.34
- Face to Face per ASME/ANSI B16.10 Short Pattern flanges design
- NACE MR0175
- Design Standard per API 608
- Markings per MSS-SP25
- Pressure Test per API 598
- Lever operated

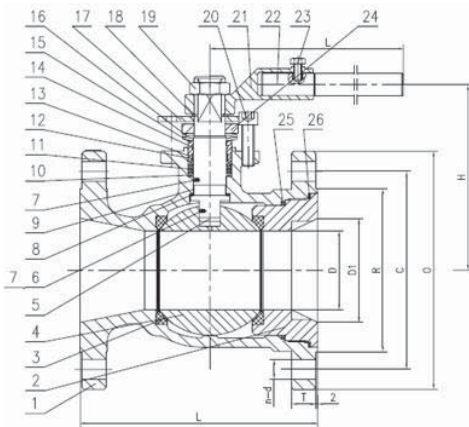

No.	Part Name	WCB Body	LCC Body
1	Body	A216 WCB	A352 LCC
2	End	A216 WCB	A352 LCC
3	Seat	R-PTFE	R-PTFE
4	Ball	A182 F316	A182 F316
5	Stem	A182 F316	A182 F316
6	Small Steel Ball	A276 304	A276 304
7	Spring	A276 304	A276 304
8	Stem Gasket	PTFE	PTFE
9	Stem Bearing	PTFE	PTFE
10	Stem Firesafe Gasket I	Flexible Graphite + 316	Flexible Graphite + 316
11	Stem Firesafe Gasket II	Flexible Graphite	Flexible Graphite
12	Packing Bushing Bearing	PTFE	PTFE
13	O-Ring	Viton	Viton
14	O-ring	Viton	Viton
15	Packing bushing	A276 316	A276 316
16	Belleville Washer	A276 304	A276 304
17	Limit Block	A36	A36
18	Axial Retaining Ring	AISI 1566	AISI 1566
19	Nut	SS	SS
20	Screw	A193 B7M	AZ350 L7M
21	Joint	A216 WCB	A352 LCC
22	Lever	AISI 1020	AISI 1020
23	Hex Bolt	CS	CS
24	But	SS	SS
25	Gasket	PTFE	PTFE
26	Gasket	Flexible Graphite + 316SS	Flexible Graphite + 316SS

Size	L	D	D1	R	C	O	n-d	T	W	H	WT	Torque		Cv
												150 PSI	285 PSI	
2" x 1-1/2" 50 x 38	7" 178	1.46" 37	1.97" 50	3.625" 92.1	4.75" 120.7	5.9" 150	4-3/4" 4-19	0.562" 14.3	9.53" 14.3	5.4" 137	22 9.7	221 in lbs 25 Nm	487 in lbs 55 Nm	130
3" x 2" 76 x 50	8" 203	1.97" 50	2.95" 75	5" 127	6" 152.4	7.48" 190	4-3/4" 4-19	0.69" 17.5	9.53" 242	6.575" 167	40 18	372 in lbs 42 Nm	620 in lbs 70 Nm	350
4" x 3" 102 x 76	9.02" 229	2.95" 75	3.98" 101	6.19 157.2	7.5" 190.5	9.05" 230	8-3/4" 8-19	0.88" 22.3	13.78" 350	8.07" 205	77 35	797 in lbs 90 Nm	1328 in lbs 150 Nm	720
6" x 4" 152 x 102	10.5" 267	3.98" 101	5.94" 151	8.5" 215.9	9.5" 241.3	11.02" 280	8-.885" 8-22.5	0.94" 23.9	18.11" 460	8.66" 220	132 60	1328 in lbs 150 Nm	2168 in lbs 245 Nm	1020
8" x 6" 203 x 152	18" 457	5.94" 151	7.95" 202	10.625" 269.9	11.75" 298.5	13.58" 345	8-.885" 8-22.5	1.06" 27	29.52" 750	12.32" 313	265 120	3009 in lbs 340 Nm	4956 in lbs 560 Nm	1800

# 300# Full Port Carbon Steel, Low Temp & SS



### Features:

- Full bore, 2 piece body floating ball
- ISO Mounting Pad
- Fire-safe to API-607. 4th Ed., blow-out proof stem
- Cavity relieving seats, anti-static device
- Designed according to ASME/ANSI Class 300 - B16.34
- Face to Face per ASME/ANSI B16.10 Long Pattern
- Flanges designed per ASME/ANSI B16.5
- NACE MR0175
- Design Standard per API 608
- Markings per MSS-SP25
- Pressure Test per API 598
- Lever operated 2"-6", Gear operated 8"

L  
E  
V  
E  
R

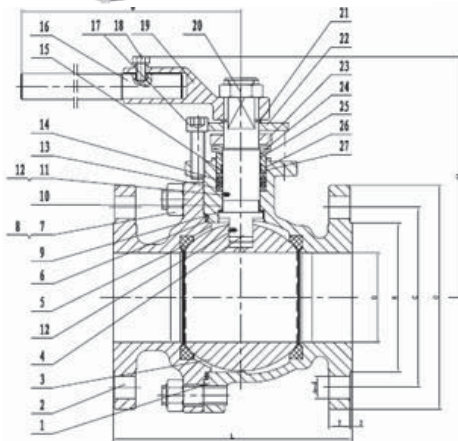

No	Part Name	WCB Body	LCC Body	316SS Body
1	Body	A216 WCB	A352 LCC	A351 CF8M
2	End	A216 WCB	A352 LCC	A351 CF8M
3	Ball	A182 F316	A182 F316	A182 F316
4	Stem	A182 F316	A182 F316	A182 F316
5	Seat	R-PTFE	R-PTFE	R-PTFE
6	Body Gasket	304 Graphite Spiral Wound	304 Graphite Spiral Wound	304 Graphite Spiral Wound
7	Nut	A194-2HM	A194-2HM	A194-8M
8	Full Threaded Bolt	A193-B7M	A320 L7M	A320 B8M
9	Stem Gasket	PTFE	PTFE	PTFE
10	Stem Bearing	PTFE	PTFE	PTFE
11	Steel Ball	A276 304	A276 304	A276 304
12	Antistatic Spring	A276 304	A276 304	A276 304
13	Stem Firesafe Gasket I	Flexible Graphite + 316	Flexible Graphite + 316	Flexible Graphite + 316
14	Stem Firesafe Gasket II	Flexible Graphite	Flexible Graphite	Flexible Graphite
15	Packing Gland Bearing	PTFE	PTFE	PTFE
16	Lever	AISI 1020	AISI 1020	AISI 1020+Zn
17	Screw	A193-B7M	A320 L7M	A193 B8M
18	Hex Bolt	A193-B7M	SS	SS
19	Joining	A216 WCB	A352 LCC	A216 WCB + Zn
20	Nut	AISI 1020	AISI 1020	SS
21	Axial Retaining Ring	AISI 1566	AISI 1566	AISI 1566
22	Limit Block	A36	A36	A36
23	Nut	AISI 1020	AISI 1020	SS
24	Belleville Washer	A276 304	A276 304	A276 304
25	O-Ring	Viton	Viton	Viton
26	O-Ring	Viton	Viton	Viton
27	Packing Bushing	A276 316	A276 316	A276 316

G  
E  
A  
R

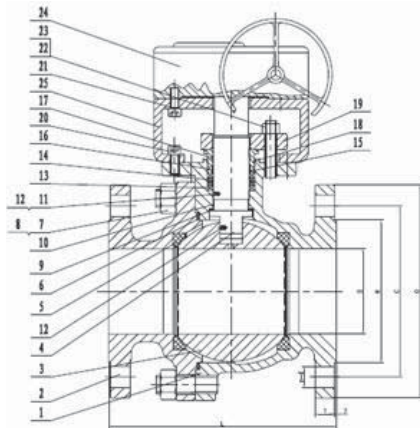

No	Part Name	WCB Body	LCC Body	316SS Body
1	Body	A216 WCB	A352 LCC	A351-CF8M
2	End	A216 WCB	A352 LCC	A351-CF8M
3	Ball	A182 F316	A182 F316	A182 F316
4	Stem	A182 F316	A182 F316	A182 F316
5	Seat	R-PTFE	R-PTFE	R-PTFE
6	Body Gasket	304 Graphite Spiral Wound	304 Graphite Spiral Wound	304 Graphite Spiral Wound
7	Nut	A194-2HM	A194-2HM	A194-8M
8	Full Threaded Bolt	A193-B7M	A320 L7M	A320 B8M
9	Stem Gasket	PTFE	PTFE	PTFE
10	Stem Bearing	PTFE	PTFE	PTFE
11	Steel Ball	A276 304	A276 304	A276 304
12	Antistatic Spring	A276 304	A276 304	A276 304
13	Stem Firesafe Gasket I	Flexible Graphite + 316	Flexible Graphite + 316	Flexible Graphite+ 316
14	Stem Firesafe Gasket II	Flexible Graphite	Flexible Graphite	Flexible Graphite
15	Packing Gland Bearing	PTFE	PTFE	PTFE
16	O-Ring	Viton	Viton	Viton
17	O-ring	Viton	Viton	Viton
18	Packing Bushing	A276 316	A276 316	A276 316
19	Packing Plate	A216 WCB	A352 LCC	A216 WCB
20	Inner Hex Screw	A193-B7M	A320 L7M	A320 B8M
21	Inner Hex Screw	A193-B7M	A320 L7M	A320 B8M
22	Nut	A194-2HM	A194 7M	A194 8M
23	Bolt	A193-B7M	A320 L7M	A320 B8M
24	Actuator	Component	Component	Component
25	Yoke	A36	A36	A36

Size	L	D	R	C	O	n-d	T	W	H	WT	Torque		Cv
											300 PSI	740 PSI	
2" 50	8.5" 216	1.97" 50	3.625" 92.1	5" 127	6.5" 165	8-3/4" 8-19	0.814" 20.7	9.53" 242	6.34" 161	35 16	664 in lbs 75 Nm	974 in lbs 100 Nm	450
3" 76	11.1" 283	2.95" 75	5" 127	6.62" 168.3	8.26" 210	8-.885" 8-22.5	1.06" 27	13.78" 350	8.07" 205	79 36	1416 in lbs 160 Nm	2478 in lbs 280 Nm	1100
4" 102	12" 305	3.98" 101	6.19" 157.2	7.87" 200	10.04" 255	8-.885" 8-22.5"	1.19" 30.2	18.11" 460	8.86" 225	132 60	2301 in lbs 260 Nm	3540 in lbs 400 Nm	2200
6" 152	15.87" 403	5.94" 151	8.5" 215.9	10.625" 269.9	12.6" 320	12-.885" 12-22.5	1.38" 35	29.53" 750	12.48" 317	260 118	4426 in lbs 500 Nm	8496 in lbs 960 Nm	5200
8" 203	19.76" 502	7.95" 202	10.625" 269.9	13" 330.2	14.96" 380	12-1" 12-25.5	1.56" 39.7			520 236	12611 in lbs 1425 Nm	13718 in lbs 1550 Nm	10,000

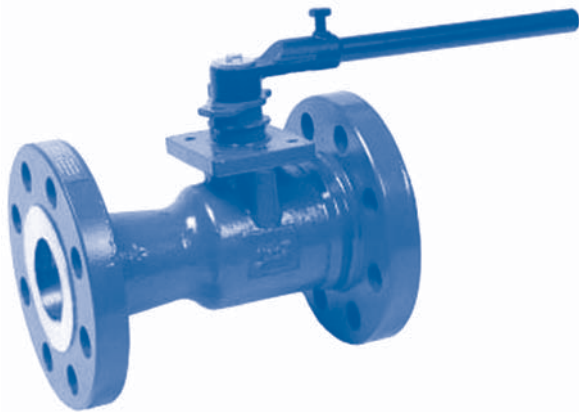

**Features:**

- Reduced bore, 1 piece unibody floating ball
- ISO Mounting Pad
- Fire-safe to API-607, 4th Ed., blow-out proof stem
- Cavity relieving seats, anti-static device
- Designed according to ASME/ANSI Class 300 - B16.34
- Face to Face per ASME/ANSI B16.10 Short Pattern flanges design
- NACE MR0175
- Design Standard per API 608
- Markings per MSS-SP25
- Pressure Test per API 598
- Lever operated

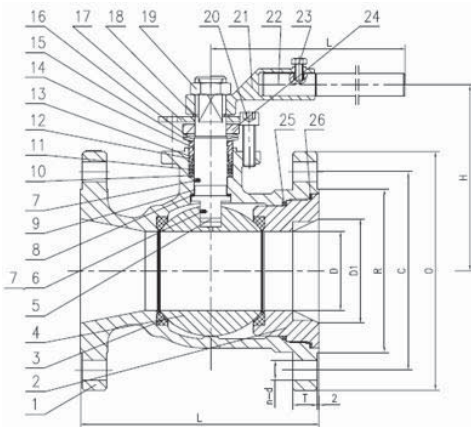

No	Part Name	WCB Body	LCC Body
1	Body	A216 WCB	A352 LCC
2	End	A216 WCB	A352 LCC
3	Seat	R-PTFE	R-PTFE
4	Ball	A182 F316	A182 F316
5	Stem	A182 F316	A182 F316
6	Small Steel Ball	A276 304	A276 304
7	Spring	A276 304	A276 304
8	Stem Gasket	PTFE	PTFE
9	Stem Bearing	PTFE	PTFE
10	Stem Firesafe Gasket I	Flexible Graphite + 316	Flexible Graphite + 316
11	Stem Firesafe Gasket II	Flexible Graphite	Flexible Graphite
12	Packing Bushing Bearing	PTFE	PTFE
13	O-Ring	VITON	VITON
14	O-Ring	VITON	VITON
15	Packing Bushing	A276 316	A276 316
16	Belleville Washer	A276 304	A276 304
17	Limit Block	A36	A36
18	Axial Retaining Ring	AISI 1566	AISI 1566
19	Nut	SS	SS
20	Screw	A193 B7M	AZ320 L7M
21	Joint	A216 WCB	A352 LCC
22	Lever	AISI 1020	AISI 1020
23	Hex Bolt	CS	CS
24	Nut	SS	SS
25	Gasket	PTFE	PTFE
26	Gasket	Flexible Graphite + 316SS	Flexible Graphite + 316SS

Size	L	D	D1	R	C	O	n-d	T	W	H	WT	Torque		Cv
												300 PSI	740 PSI	
2" x 1-1/2" 50 x 38	8.5" 216	1.46" 37	1.97" 50	3.625" 92.1	5" 127	6.5" 165	8-3/4" 8-19	0.814" 20.7	9.53" 242	5.4" 137	33 15	575 in lbs 65 Nm	841 in lbs 95 Nm	130
3" x 2" 76 x 50	11.1" 283	1.97" 50	2.95" 75	5" 127	6.62" 168.3	8.26" 210	8-.885" 8-22.5	1.06" 27	9.53" 242	6.575" 167	69 31.2	664 in lbs 75 Nm	974 in lbs 110 Nm	350
4" x 3" 102 x 76	12" 305	2.95" 75	3.98" 101	6.19" 157.2	7.87" 200	10.04" 255	8-.885" 8-22.5	1.19" 30.2	13.78" 350	8.07" 205	126 57	1415 in lbs 160 Nm	2478 in lbs 280 Nm	720
6" x 4" 152 x 102	15.87" 403	3.98" 101	5.94" 151	8.5" 215.9	10.625" 269.9	12.6" 320	12-.885" 12-22.5	1.38" 35	18.11" 460	8.66" 220	183 83	2301 in lbs 260 Nm	3540 in lbs 400 Nm	1020

# 600# Full Port Carbon Steel & Low Temp

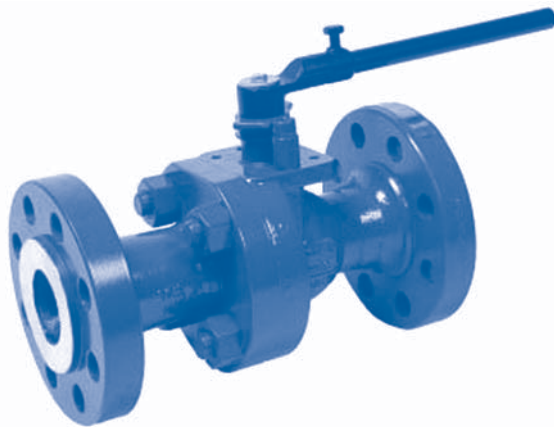

### Features:

- Full bore, 2 piece split body floating ball
- ISO Mounting Pad
- Fire-safe to API-607, 4th Ed., blow-out proof stem
- Anti-static device
- Designed according to ASME/ANSI Class 600 - B16.34
- Face to Face per ASME/ANSI B16.10 Long Pattern
- Flanges designed per ASME/ANSI B16.5
- NACE MR0175
- Design Standard per API 608
- Markings per MSS-SP25
- Pressure Test per API 598
- Lever operated

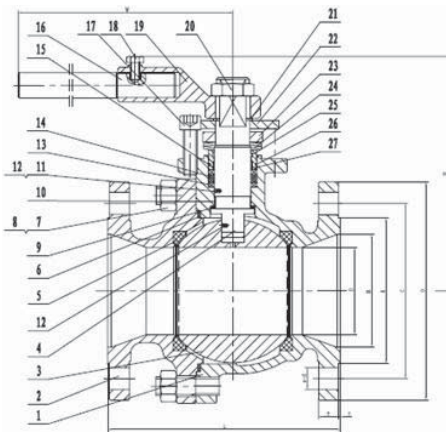

No.	Part Name	WCB Body	LCC Body
1	Body	A216 WCB	A352 LCC
2	End	A216 WCB	A352 LCC
3	Ball	A182 F316	A182 F316
4	Stem	A182 F316	A182 F316
5	Seat	Nylon	Nylon
6	Body Gasket	304 Graphite Spiral Wound	304 Graphite Spiral Wound
7	Nut	A194-2HM	A194-2HM
8	Full Threaded Bolt	A193-B7M	A320 L7M
9	Stem Gasket	PTFE	PTFE
10	Stem Bearing	PTFE	PTFE
11	Steel Ball	A276 304	A276 304
12	Anti-static Spring	A276 304	A276 304
13	Stem Firesafe Gasket I	Flexible Graphite + 316	Flexible Graphite + 316
14	Stem Firesafe Gasket II	Flexible Graphite	Flexible Graphite
15	Packing Gland Bearing	PTFE	PTFE
16	Lever	AISI 1020	AISI 1020
17	Screw	A193-B7M	A320 L7M
18	Hex Bolt	A193-B7M	SS
19	Joint	A216 WCB	A352 LCC
20	Nut	AISI 1020	AISI 1020
21	Axial Retaining Ring	AIAI 1566	AIAI 1566
22	Limit Block	A36	A36
23	Nut	AISI 1020	AISI 1020
24	Belleville Washer	A276 304	A276 304
25	O-Ring	Viton	Viton
26	O-Ring	Viton	Viton
27	Packing Bushing	A276 316	A276 316

Size	L	D	R	C	O	n-d	T	W	H	WT	Torque		Cv
											600 PSI	1440 PSI	
2" 50	11.5" 292	1.97" 50	3.625" 92.1	5" 127	6.5" 165	8-3/4" 8-19	1" 25.4	17" 432	6.14" 156	42 19	841 in lbs 95 Nm	1682 in lbs 190 Nm	450
3" 76	14" 356	2.95" 75	5" 127	6.62" 168.3	8.26" 210	8-.885" 8-22.5	1.25" 31.8	21.65" 550	8.22" 309	99 45	2080 in lbs 235 Nm	4071 in lbs 460 Nm	1100
4" 102	17" 432	3.98" 101	6.19" 157.2	8.5" 215.9	10.82" 275	8-1" 8-25.5	1.5" 38.1	33.46" 850	11.02" 280	167 76	2567 in lbs 290 Nm	5089 in lbs 575 Nm	2200



**Features:**

- Reduced bore, 2 piece split body floating ball
- ISO Mounting Pad
- Fire-safe to API-607, 4th Ed., blow-out proof stem
- Anti-static device
- Designed according to ASME/ANSI Class 600 - B16.34
- Face to Face per ASME/ANSI B16.10 Long Pattern
- Flanges designed per ASME/ANSI B16.5
- NACE MR0175
- Design Standard per API 608
- Markings per MSS-SP25
- Pressure Test per API 598
- Lever operated 2"-4", Gear operated 6"

L  
E  
V  
E  
R

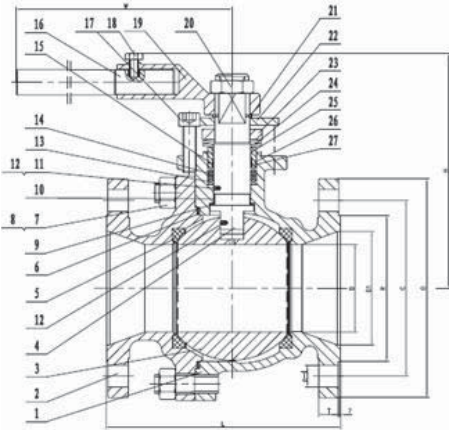

No.	Part Name	WCB Body	LCC Body
1	Body	A216 WCB	A352 LCC
2	End	A216 WCB	A352 LCC
3	Ball	A182 F316	A182 F316
4	Stem	A182 F316	A182 F316
5	Seat	Nylon	Nylon
6	Body Gasket	304 Graphite Spiral Wound	304 Graphite Spiral Wound
7	Nut	A194-2HM	A194-2HM
8	Full Threaded Bolt	A193-B7M	A320 L7M
9	Stem Gasket	PTFE	PTFE
10	Stem Bearing	PTFE	PTFE
11	Steel Ball	A276 304	A276 304
12	Anti-static Spring	A276 304	A276 304
13	Stem Firesafe Gasket I	Flexible Graphite + 316	Flexible Graphite + 316
14	Stem Firesafe Gasket II	Flexible Graphite	Flexible Graphite
15	Packing Gland Bearing	PTFE	PTFE
16	Lever	AISI 1020	AISI 1020
17	Screw	A193-B7M	A320 L7M
18	Hex Bolt	A193-B7M	SS
19	Joint	A216 WCB	A352 LCC
20	Nut	AISI 1020	AISI 1020
21	Axial Retaining Ring	AIAI 1566	AIAI 1566
22	Limit Block	A36	A36
23	Nut	AISI 1020	AISI 1020
24	Belleville Washer	A276 304	A276 304
25	O-Ring	Viton	Viton
26	O-Ring	Viton	Viton
27	Packing Bushing	A276 316	A276 316

G  
E  
A  
R

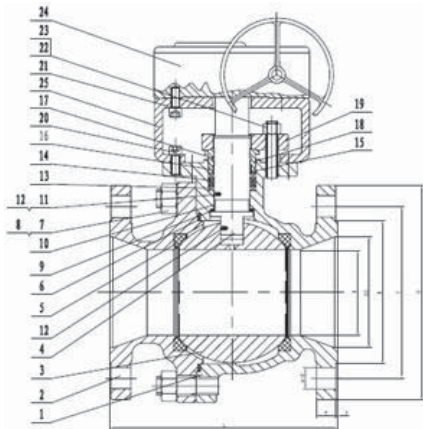

No.	Part Name	WCB Body	LCC Body
1	Body	A216 WCB	A352 LCC
2	End	A216 WCB	A352 LCC
3	Ball	A182 F316	A182 F316
4	Stem	A182 F316	A182 F316
5	Seat	Nylon	Nylon
6	Body Gasket	304 Graphite Spiral Wound	304 Graphite Spiral Wound
7	Nut	A194-2HM	A194-2HM
8	Full Threaded Bolt	A193-B7M	A320 L7M
9	Stem Gasket	PTFE	PTFE
10	Stem Bearing	PTFE	PTFE
11	Steel Ball	A276 304	A276 304
12	Anti-static Spring	A276 304	A276 304
13	Stem Firesafe Gasket I	Flexible Graphite + 316	Flexible Graphite + 316
14	Stem Firesafe Gasket II	Flexible Graphite	Flexible Graphite
15	Packing Gland Bearing	PTFE	PTFE
16	O-Ring	Viton	Viton
17	O-Ring	Viton	Viton
18	Packing Bushing	A276 316	A276 316
19	Packing Plate	A216 WCB	A352 LCC
20	Inner Hex Screw	A193-B7M	A320 L7M
21	Inner Hex Screw	A193-B7M	A320 L7M
22	Nut	A194-B7M	A194 7M
23	Bolt	A193-B7M	A320 L7M
24	Actuator Component	Component	Component
25	Yoke	A36	A36

Size	L	D	D1	R	C	O	n-d	T	W	H	WT	Torque		Cv
												600 PSI	1440 PSI	
2" x 1-1/2" 50 x 38	11.5" 292	1.46" 37	1.97" 50	3.625" 92.1	5" 127	6.5" 165	8-3/4" 8-19	1" 25.4	9.53" 242	5.4" 137	40 18.2	664 in lbs 75 Nm	1328 in lbs 150 Nm	130
3" x 2" 76 x 50	14" 356	1.97" 50	2.95" 75	5" 127	6.62" 168.3	8.26" 210	8-.885" 8-22.5	1.25" 31.8	13.78" 350	7.56" 192	77 35	841 in lbs 95 Nm	1682 in lbs 190 Nm	350
4" x 3" 102 x 76	17" 432	2.95" 75	3.98" 101	6.19" 157.2	8.5" 215.9	10.82" 275	8-1" 8-25.5	1.5" 38.1	21.65" 550	8.22" 209	165 75	2080 in lbs 235 Nm	4071 in lbs 460 Nm	720
6" x 4" 152 x 102	22" 559	3.98" 101	5.94" 151	8.5" 215.9	11.5" 292.1	13.98" 355	12-1.12" 12-28.5	1.88" 47.7			342 155	2567 in lbs 290 Nm	5089 in lbs 575 Nm	1020

# SPNII Actuator Information



## SPN II 050-240

## SPN II 265

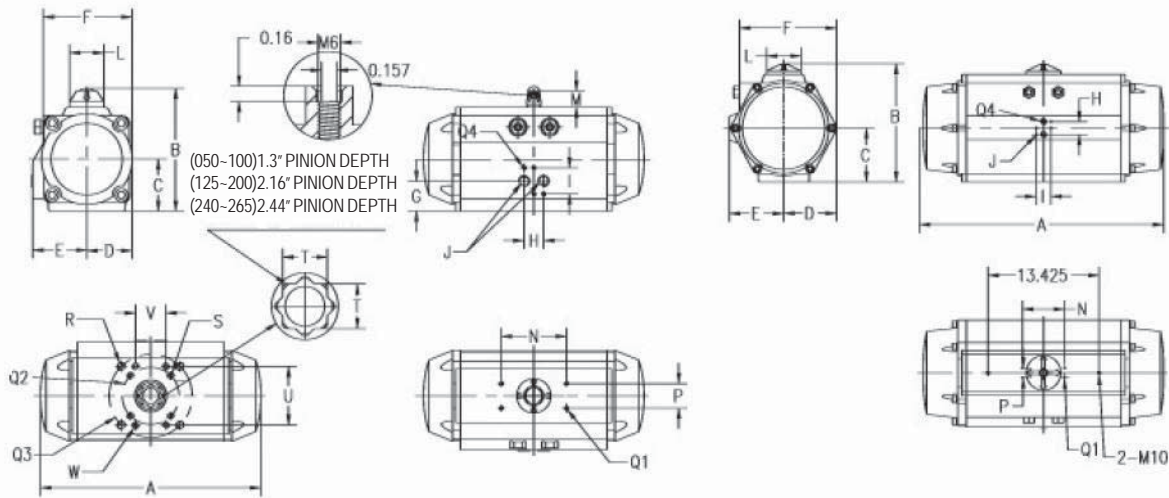

Model	032	050	063	075	085	100	125	145	160	180	200	240	265
A	4.61	5.8	6.26	8.39	9.80	10.67	13.62	16.22	17.44	19.37	21.54	24.57	29.06
B	1.77	3.62	4.25	4.92	5.43	5.94	7.48	8.25	9.06	9.96	10.91	13.11	14.33
C	X	1.35	1.67	2.01	2.27	2.50	3.09	3.46	3.87	4.33	4.80	5.91	6.50
D	X	1.12	1.42	1.71	1.91	2.20	2.72	3.15	3.46	3.88	4.29	4.84	6.40
E	X	1.61	1.14	2.07	2.22	2.60	3.23	3.54	3.87	4.15	4.41	5.18	6.57
F	1.77	2.28	2.83	3.39	3.80	4.17	5.12	5.85	6.28	7.07	7.64	9.11	11.73
G	X	1.02	1.18	1.03	1.26	1.46	1.80	2.17	2.04	2.37	2.60	3.09	-
H	0.94	0.94	0.94	0.94	0.94	0.94	0.94	0.94	0.94	0.94	0.94	1.57	1.57
I	1.25	1.26	1.26	1.26	1.26	1.26	1.26	1.26	1.26	1.26	1.26	1.77	1.77
J	1/8"	1/4"	1/4"	1/4"	1/4"	1/4"	1/4"	1/4"	1/4"	1/4"	1/4"	3/8"	3/8"
L	1.4	1.65	1.65	1.65	1.65	1.65	2.60	2.60	2.60	3.15	3.15	4.17	4.17
M	0.79	0.79	0.79	0.79	0.79	0.79	0.79	1.18	1.18	1.18	1.18	1.97	1.97
N	1.97	3.15	3.15	3.15	3.15	3.15	3.15	3.15	3.15	5.12	5.12	5.12	5.12
P	1.18	1.18	1.18	1.18	1.18	1.18	1.18	1.18	1.18	1.18	1.18	1.18	1.18
Q1	M5	M5	M5	M5	M5	M5	M5	M5	M5	M5	M5	M5	M5
Q2	1.43	1.65	1.97	1.97	1.97	2.76	4.02	4.02	4.02	4.02	4.02	4.92	-
Q3	X	X	X	2.76	2.76	4.02	X	4.92	4.92	5.51	5.51	6.50	6.50
Q4	M5	M5	M5	M5	M5	M5	M5	M5	M5	M5	M5	M5	M6
R	X	X	X	M8	M8	M10	X	M12	M12	M16	M16	M20	M20
S	M5	M5	M6	M6	M6	M8	M10	M10	M10	M10	M10	M12	-
T	0.35	0.67	0.67	0.87	0.87	0.87	1.42	1.42	1.42	1.42	1.42	1.81	1.81
U	X	X	X	X	X	2.83	2.83	2.83	2.83	3.90	3.90	-	-
V	X	X	X	X	X	1.46	1.46	1.46	1.46	2.09	2.09	-	-
W	X	X	X	X	X	M8	M8	M8	M8	M10	M10	-	-

## Actuation Selection Chart

For ISO Direct Mount Ball Valves Only (B03, B05/5S/5TC, B07L/T & ZF1 SS only)*								
Size	1/2"	3/4"	1"	1-1/2"	2"	3"	4"	6"
Double Acting Actuator (DA)	SPNII50DA	SPNII63DA	SPNII63DA	SPNII75DA	SPNII75DA	SPNII100DA	SPNII100DA	SPNII145DA
Spring Return Actuator (SR)	SPNII50SR	SPNII63SR	SPNII75SR	SPNII75SR	SPNII85SR	SPNII100SR	SPNII125SR	SPNII160SR
Valve Torque ** (in. lbs)	85	110	180	315	450	680	1190	2850

\* Actuator sized for liquid service up to 500 psig differential line pressure using 80 psig instrument air.

\*\* Actuator sizing torques up to 500 psig DP, Water - 1.0, Oil - 0.8, Gas Wet (Steam) - 1.0, Gas Dry - 1.3.

\*\*\* Add 20% on torque values for 3-way B07 series valve.

\*\*\*\* For high or low temperature applications consult supplier for special seal kits.

# Warranty

VSTC-09

**EFFECTIVE OCTOBER 1, 2009, TERMS AND CONDITIONS OF SALE WILL APPLY TO ALL PRODUCTS SOLD BY THE VALVSOURCE GROUP OF COMPANIES**

**CANCELLATIONS & RETURNED PRODUCTS:** This policy covers only Products of current manufacture, design, and normally stocked items in new condition. Cancelled orders will be subject to a charge minimum of 35%. All sales are final; all custom products (non-stocking) are not subject to return, credit or refund. The return of obsolete and used Products shall not be permitted. The Purchaser shall not return Products without first obtaining Seller's written permission and shall be subject to a restocking charge. Products must be returned within 10 days after the date that written permission has been given. All transportation charges for any returned Products shall be paid by the Purchaser. Request to return Products must be accompanied by relevant customer order and Seller's invoice number(s). Final acceptance of returned Products is subject to examination and/or testing. Products will not be accepted for return or credit later than six (6) months after invoicing.

**NO RIGHTS OF CANCELLATION:** The parties acknowledge and agree that the Purchaser shall not have the right to cancel or reject any shipment of Products not delivered within the delivery time specified in this Purchase Agreement. In the event the Purchaser fails or refuses to accept delivery of the Products, Seller shall have the right to cancel this Agreement whereupon all deposit monies paid by Purchaser shall be retained by Seller as liquidated damages and not as penalty and without prejudice to any rights of Seller to claim for all additional costs, expenses and damages Seller may suffer or incur as a result of such cancellation. The Purchaser understands that if the Products described in this Agreement are specially designed and custom built the Seller takes immediate steps upon execution of this Agreement to design order and construct those items set forth herein.

**PRICES:** Possession of price lists will not be accepted by the Seller as an obligation, or offer, to sell any goods listed therein. All prices contained in published price lists are subject to change without notice and supersede those of all previous lists.

**SALES TAXES, ETC.:** The Purchaser shall pay and be responsible for all provincial, local or federal sales, use or other taxes (including general sales or value added taxes) and customs duties now or hereinafter enacted which may be applicable to the sale of the Products or the importation of the Products to the destination specified by the Purchaser and which duties and taxes shall be the responsibility of the Purchaser.

**CREDIT APPROVAL:** Orders are accepted subject to satisfactory credit approval. Pending credit approval, delivery may be delayed without liability to Seller.

**TERMS OF PAYMENT:** The terms of payment for Products purchased pursuant to this Agreement are (I) upon acceptance of the purchase order a deposit in such amount as may be set out in the Seller's written acceptance notice and (II) the balance within 30 days from the date of invoice. Any invoice amount which is not paid when due shall bear interest at the rate of one and one-half (1 ½%) percent per month until paid in full. The Purchaser agrees that it will not have any rights of set off against or deduction from the purchase price for the Products payable by the Purchaser pursuant to this Agreement. The Purchaser grants to Seller a purchase money security interest in all Products delivered pursuant to this Agreement and all proceeds thereof (whether cash or non-cash and including, without limitation, accounts, instruments and chattel paper). Any failure by the Purchaser to pay the purchase price in full as provided in this Agreement shall constitute an event of default for purposes of said security interest. Upon the occurrence of any such default, Seller shall have all rights of a secured party after default under applicable law. Any repossession and removal of any Products shall be without prejudice to any of Seller's other remedies at law or in equity. The Purchaser agrees, without further consideration, at any time, to do or cause to be done, to execute and deliver, all such further acts and instruments (including, without limitation, financing statements approved for filing) as Seller may reasonably request in order to perfect Seller's security interest.

**DELIVERY DATE:** Seller will utilize reasonable best efforts to meet the delivery schedules stipulated in this Agreement. In the event the provisions of Section 13 hereof shall apply, the delivery date shall be extended by a number of days that is equal to the duration of the event or condition that is responsible for such delay.

**F.O.B. AND SHIPMENT:** Seller shall deliver the Products to the Purchaser F.O.B. Seller's warehouse. Risk of loss or damage to the Products shall pass to the Purchaser at the F.O.B. point upon transfer of possession to the carrier for delivery to the Purchaser. Loss of or destruction of or damage to the Products from and after the time they are received by the carrier for delivery to the Purchaser shall not in any way release, reduce or in any way affect the Purchaser's responsibility to pay the full purchase price thereof in accordance with the provisions of this Agreement. Seller is not responsible for its selection of the carrier or the mode of shipment.

**INSPECTION BY PURCHASER:** All Products must be inspected by the Purchaser upon receipt and the Purchaser and Seller, collectively, agree to file appropriate claims with the carrier when there is evidence of shipping damage, either concealed or external. Claims for shortage or error in shipment or for damage other than shipping damage must be made within 5 days after receipt of shipment, failing which the Purchaser shall be deemed to have accepted the shipment.

**LIMITED WARRANTY:** Purchaser acknowledges that the Products are provided to the Purchaser subject only to the limited warranties provided by the manufacturer of the Products and are subject to all of the conditions, limitations and exclusions set out therein, all of which are hereby accepted by the Purchaser. The warranty exclusions include, without limitation, (I) any defects caused by faulty installation performed by Purchaser or third parties, (II) any damage caused by the contractors or tradesman of the Purchaser, (III) any damage caused by improper use or misuse, including exposure to excessive temperatures, moisture or cleaning agents and solvents and (IV) any damage caused during transportation or improper storage. Claims for warranty repairs and replacements must be made within the applicable time period described in the manufacturer's limited warranty. In no event shall Seller be liable for other than the repair or replacement of any defective Products. In no event shall Seller be liable for any damages, direct or indirect, special or consequential, including, without limitation, damages for lost profits, business interruption, or economic loss arising out of defects in the Products.

**EXCLUSION OF WARRANTIES:** Except as expressly set forth herein seller disclaims all warranties with regard to the products including, without limitation, all implied warranties of merchantability and fitness for a particular purpose.

**CATALOGUE AND OTHER PRINTED MATTER:** Seller's illustrations are representations of a certain size of each line of Product, but do not necessarily represent all sizes and materials in detail. Similarly, dimensions, weights and material information have been prepared with care, but their correctness is not guaranteed. Seller reserves the right to vary the designs and dimensions without notice.

**FORCE MAJEURE:** Any delay or failure of performance by Seller shall be excused if and to the extent caused, directly or indirectly, events beyond Seller's control including, without limitation, fire, flood earthquake, lightning, hurricane, explosion, accident or breakdown, acts of God, embargo, strike, labour dispute, labour trouble, lockout, shortage or control of power supply, shortage of supplies or raw materials, or any causes whether of the same kind as the causes enumerated before or not. Subject to any express provisions of this Agreement, any such causes of delay shall extend the time of performance by the length of delay occasioned thereby.

**NO WAIVER:** No waiver by Seller of any right hereunder or of any right granted in connection with a failure to perform or breach by the Purchaser shall be deemed as a waiver of any other right hereunder or of any right granted in connection with any other failure or breach by the Purchaser, whether of a similar nature or otherwise.

**NOTICE:** Any notice made under or in relation to this Agreement shall be sent to the addresses first above written or such other address as the intended recipient shall have previously designated by written notice, by postage prepaid registered mail or by telegram including telex, followed by a confirmation letter by postage prepaid and return receipt requested registered mail. The notice shall be deemed to be made on the fifth day following the date of mailing.

**ENTIRE AGREEMENT:** This Agreement contains the entire agreement and understanding of the parties hereto with respect to the subject matter of this Agreement, and supersedes all prior discussions, agreements, understandings of any and every nature, whether written or oral, between the parties with respect to the subject matter of this Agreement, and no condition, definition, warranty or representation other than those expressly provided for in this Agreement with respect to the subject matter of this Agreement shall be binding upon either party hereto.

**AMENDMENTS IN WRITING:** Any amendment, modification, change or alteration of this Agreement shall be made in writing which expressly refers to this Agreement and which is signed by a duly authorized officer or representative of each of the parties hereto.

**SEVERABILITY:** All provisions of this Agreement are severable and this Agreement shall be interpreted and enforced as if all completely invalid or unenforceable provisions were not contained herein. All partially valid and enforceable provisions shall be enforced to the extent they are valid and enforceable.

**NO AGENCY OR PARTNERSHIP:** Nothing herein contained shall be deemed or construed to constitute either party the agent or partner of the other. Neither party shall have any right, title or authority to enter into any contract, agreement or commitment on behalf of the other or to bind the other in any manner whatsoever.

**GOVERNING LAW:** This agreement shall be governed by and construed in accordance with the laws of the jurisdiction from which the products are shipped by the seller to the purchaser and the parties hereby attach to the courts of such jurisdiction.

**ENUREMENT:** This Agreement shall enure to the benefit of and be binding upon the parties hereto and on their successors and permitted assigns.

**SELLER DEFINED:** For the purposes hereof, Seller means the Corporation listed as such on the front page of the Invoice or acceptance notice of which these terms and conditions of sale form a part.

## Contact Information

Your local Sales Representative: